

UpRight

POWERED ACCESS



X26-32

WORK PLATFORM

PN: 504164-005
sn: 53117+
Feb 2010

SERVICE & PARTS MANUAL

X 26-32

ENGLISH

When contacting **Upright** for service or parts information, be sure to include the MODEL and SERIAL NUMBERS from the equipment nameplate. Should the nameplate be missing, the SERIAL NUMBER is also stamped on top of the chassis above the front axle pivot.

The diagram shows a scissor lift chassis with two nameplates. The top nameplate is for model X26 and the bottom for model X32. A callout box points to the stamped serial number on the chassis above the front axle pivot.

UpRight		VIGO CENTRE WASHINGTON TYNE & WEAR, UK		CE
MODEL	X26	SERIAL No.		
MAX. PLATFORM HEIGHT	7.93 m	YEAR OF MANUFACTURE		
MAX. PLATFORM LOAD	454 Kg = 4 Persons + Equipment Indoor 200N outdoors			
MAX. LATERAL FORCE	400N indoors 200N outdoors	MAX. WIND SPEED	12.5m/s	
MAX. CHASSIS INCLINATION	2°	BATTERY VOLTAGE	24V	
UNLADEN WEIGHT	2290 Kg	CHARGER INPUT VOLTAGE	110/220V	
MAX. GRADEABILITY	25%	NOMINAL POWER	3 kW	
CAUTION: ONLY TRAINED & AUTHORISED PERSONNEL MAY USE THIS MACHINE—CONSULT OPERATORS MANUAL BEFORE USE. THIS PLATFORM IS NOT ELECTRICALLY INSULATED 504197-004				

UpRight		VIGO CENTRE WASHINGTON TYNE & WEAR, UK		CE
MODEL	X32	SERIAL No.		
MAX. PLATFORM HEIGHT	9.63 m	YEAR OF MANUFACTURE		
MAX. PLATFORM LOAD	340 Kg = 3 Persons + Equipment Indoor 400N Outdoors			
MAX. LATERAL FORCE	400N indoors 400N Outdoors	MAX. WIND SPEED	7 m/s	
MAX. CHASSIS INCLINATION	2°	BATTERY VOLTAGE	24V	
UNLADEN WEIGHT	2580 Kg	CHARGER INPUT VOLTAGE	110/220V	
MAX. GRADEABILITY	25%	NOMINAL POWER	3 kW	
CAUTION: ONLY TRAINED & AUTHORISED PERSONNEL MAY USE THIS MACHINE—CONSULT OPERATORS MANUAL BEFORE USE. THIS PLATFORM IS NOT ELECTRICALLY INSULATED 504198-004				

Stamped Serial Number
Estampille de numéro de série
Eingestanzte Seriennummer

UpRight
POWERED ACCESS

www.upright.com

PART NUMBER : 504164-004

SERIAL NUMBER : 53100

FORWARD

HOW TO USE THIS MANUAL

This manual is divided into six sections.

SECTION 1 INTRODUCTION

General description and machine specifications.

SECTION 2 OPERATION AND SPECIFICATION

Information on how to operate the work platform and how to prepare it for operation.

SECTION 3 MAINTENANCE

Preventative maintenance and service information.

SECTION 4 TROUBLESHOOTING

Causes and solutions to typical problems.

SECTION 5 SCHEMATICS

Schematics and valve block diagram with description and location of components.

SECTION 6 ILLUSTRATED PARTS BREAKDOWN

Complete parts lists with illustrations.

SPECIAL INFORMATION

⚠ DANGER ⚠

Indicates an imminently hazardous situation which, if not avoided, will result in death or serious injury.

⚠ WARNING ⚠

Indicates a potentially hazardous situation which, if not avoided, could result in death or serious injury.

⚠ CAUTION ⚠

Indicates a potentially hazardous situation which, if not avoided, may result in minor or moderate injury.

NOTE: Gives helpful information.

WORKSHOP PROCEDURES

All information contained in this manual is based on the latest product information available at the time of printing. We reserve the right to make changes at any time without notice.

No part of this publication may be reproduced, stored in retrieval system, or transmitted, in any form by any means, electronic, mechanical, photocopying, recording, or otherwise, without the prior written permission of the publisher. This includes text, figures and tables.

CAUTION

Detailed descriptions of standard workshop procedures, safety principles and service operations are not included.

Please note that this manual does contain warnings and cautions against some specific service methods which could cause personal injury or could damage a machine or make it unsafe.

*Please understand that these warnings cannot cover all conceivable ways in which service, whether or not recommended by **UpRight**, might be done, or of the possible hazardous consequences of each conceivable way, nor could **UpRight**, investigate all such ways.*

*Anyone using service procedures or tools, whether or not recommended by **UpRight**, must satisfy themselves thoroughly that neither personal safety nor machine safety will be jeopardized.*

INTRODUCTION

1.1 INTRODUCTION

PURPOSE

The purpose of this service and parts manual is to provide instructions and illustrations for the operation and maintenance of this work platform manufactured by **UpRight**.

SCOPE

The manual includes procedures for proper operation, maintenance, adjustment, and repair of this product as well as recommended maintenance schedules and troubleshooting.

1.2 GENERAL DESCRIPTION

The work platform consists of the platform, controller, elevating assembly, power module, control module, and chassis.

⚠ WARNING ⚠

DO NOT use the work platform without guardrails properly assembled and in place.

Figure 1-1: X26-32

PLATFORM

The platform has a reinforced steel floor, 1.1m (43.5 inch) high guardrails with midrail, 152 mm (6 inch) toe-boards, and an entry chain at the rear of the platform. The guardrails can be folded down for access through doors or for shipment.

PLATFORM CONTROLLER

The platform controller contains the controls to operate the machine. It is located at the front of the platform cage. A complete explanation of control functions can be found in Section 2.

ELEVATING ASSEMBLY

The platform is raised and lowered by the elevating assembly. The hydraulic pump, driven by the engine, powers the cylinder. Solenoid operated valves control raising and lowering.

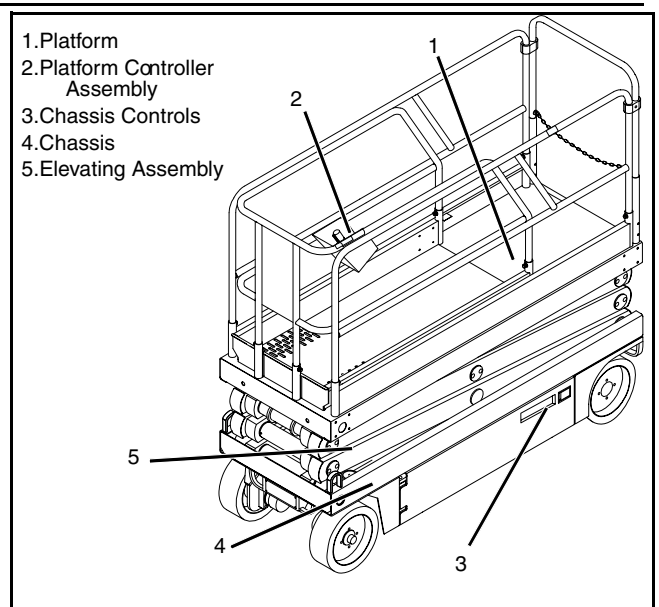

CHASSIS

The chassis is a structural frame that supports all the components of the X26-32 work platform.

PURPOSE OF EQUIPMENT

The objective of the work platform is to provide a quickly deployable, self-propelled, variable height work platform to elevate personnel and materials to overhead work areas.

SPECIAL LIMITATIONS

Travel with the platform raised is limited to a creep speed range.

Elevating of the work platform is limited to firm, level surfaces only.

Any degree of slope greater than 3° will sound a warning alarm when the machine is elevated.

D A N G E R

The elevating function shall ONLY be used when the work platform is level and on a firm surface.

The work platform is NOT intended to be driven over uneven, rough, or soft terrain when elevated.

2. OPERATION MANUAL

WARNING

All personnel shall carefully read, understand and follow all safety rules and operating instructions before operating or performing maintenance on any UpRight aerial work platform.

Safety Rules

Electrocution Hazard

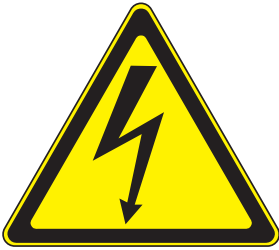

THIS MACHINE IS NOT INSULATED!

Tip Over Hazard



NEVER elevate the platform or drive the machine while elevated unless the machine is on a firm, level surface.

Collision Hazard



NEVER position the platform without first checking for overhead obstructions or other hazards.

Fall Hazard

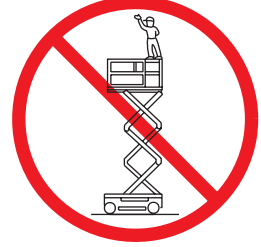

NEVER climb, stand, or sit on platform guardrails or midrail.

USE OF THE AERIAL WORK PLATFORM: This aerial work platform is intended to lift persons and his tools as well as the material used for the job. It is designed for repair and assembly jobs and assignments at overhead workplaces (ceilings, cranes, roof structures, buildings etc.). All other uses of the aerial work platform are prohibited!

THIS AERIAL WORK PLATFORM IS NOT INSULATED! For this reason it is imperative to keep a safe distance from live parts of electrical equipment!

Exceeding the specified permissible maximum load **is prohibited!** See “Special Limitations” on page 4 for details.

The use and operation of the aerial work platform as a lifting tool or a crane (lifting of loads from below upwards or from up high on down) **is prohibited!**

NEVER exceed the manual force allowed for this machine. See “Special Limitations” on page 4 for details.

DISTRIBUTE all platform loads evenly on the platform.

NEVER operate the machine without first surveying the work area for surface hazards such as holes, drop-offs, bumps, curbs, or debris; and avoiding them.

OPERATE machine only on surfaces capable of supporting wheel loads.

NEVER operate the machine when wind speeds exceed this machine’s wind rating. See “Beaufort Scale” on page 4 for details.

IN CASE OF EMERGENCY push EMERGENCY STOP switch to deactivate all powered functions.

IF ALARM SOUNDS while platform is elevated, STOP, carefully lower platform. Move machine to a firm, level surface.

Climbing up the railing of the platform, standing on or stepping from the platform onto buildings, steel or prefab concrete structures, etc., **is prohibited!**

Dismantling the swing gate or other railing components **is prohibited!** Always make certain that the swing gate is closed and securely locked!

It is prohibited to keep the swing gate in an open position (held open with tie-straps) when the platform is raised!

To extend the height or the range by placing of ladders, scaffolds or similar devices on the platform **is prohibited!**

NEVER perform service on machine while platform is elevated without blocking elevating assembly.

INSPECT the machine thoroughly for cracked welds, loose or missing hardware, hydraulic leaks, loose wire connections, and damaged cables or hoses before using.

VERIFY that all labels are in place and legible before using.

NEVER use a machine that is damaged, not functioning properly, or has damaged or missing labels.

To bypass any safety equipment **is prohibited** and presents a danger for the persons on the aerial work platform and in its working range.

NEVER charge batteries near sparks or open flame. Charging batteries emit explosive hydrogen gas.

Modifications to the aerial work platform **are prohibited** or permissible only at the approval by **UpRight**.

AFTER USE, secure the work platform from unauthorized use by turning both keyswitches off and removing key.

The driving of MEWPs on the public highways is subject to regulations made under the Road Traffic Acts.

CONTENTS

Introduction	3
General Description	3
Special Limitations	4
Platform Capacity	4
Manual Force	4
Beaufort Scale	4
Lift Overload Alarm	4
Controls and Indicators	5
Pre-Operation Safety Inspection	6
System Function Inspection	7
Operation	8
Platform Extension	8
Travel With the Platform Lowered	8
Steering	8
Elevating the Platform	8
Travel With the Platform Elevated	9
Lowering the Platform	9
Emergency Lowering	9
X26	9
X32	9
Lower the Guardrails, X26	10
Lowering Procedure	10
Raising Procedure	10
Fold Down guardrails, X32	11
Fold Down Procedure	11
Erection Procedure	11
Towing or Winching	12
Parking Brake Release	12
After Use Each Day	12
Hour Meter	12
Transporting the Work Platform	13
Preparation for Shipment	13
Lifting By Crane	13
By Forklift	13
Driving or Winching onto a Truck or Trailer	13
Maintenance	14
Blocking The Elevating Assembly	14
Scissor Brace Installation	14
Scissor Brace Stowage	14
Battery Maintenance	15
Battery Charging	15
Inspection and Maintenance Schedule	16
Daily Preventative Maintenance Checklist	16
Labels	17
Specifications	19

INTRODUCTION

This manual covers operation of the X 26-32 Self-Propelled Work Platforms.

This manual must be stored on the machine at all times.

GENERAL DESCRIPTION

⚠ WARNING ⚠

DO NOT use the maintenance platform without guardrails properly assembled and in place

1. Platform
2. Elevating Assembly
3. Chassis
4. Power Module
5. Control Module
6. Platform Controls
7. Manual Case
8. Chassis Controls
9. Hydraulic Fluid Reservoir
10. Batteries

Figure 1: X 26-32

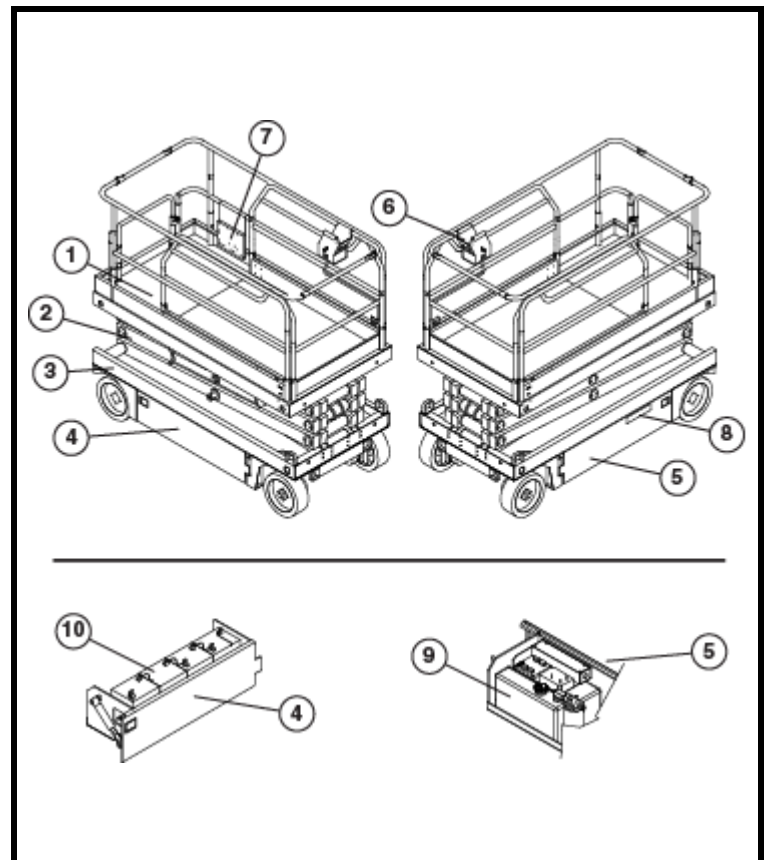

SPECIAL LIMITATIONS

Travel with the platform raised is limited to creep speed range.

Elevating the Work Platform is limited to firm, level surfaces only.



*The elevating function shall ONLY be used when the work platform is level and on a firm surface.
The work platform is NOT intended to be driven over uneven, rough, or soft terrain.*

PLATFORM CAPACITY

The maximum capacity for the MACHINE, including occupants is determined by model and options, and is listed in "Decals" on page 18.



DO NOT exceed the maximum platform capacity or the platform occupancy limits for this machine.

MANUAL FORCE

Manual force is the force applied by the occupants to objects such as walls or other structures outside the work platform.

The maximum allowable manual force is limited to 200 N (45 lbs.) of force per occupant, with a maximum of 400 N (90 lbs.) for two or more occupants.



DO NOT exceed the maximum amount of manual force for this machine.

BEAUFORT SCALE

Never operate the X32 machine when wind speeds exceed 7m/s [Beaufort scale 4].

Never operate the X26 machine when wind speeds exceed 12.5m/s [Beaufort scale 6].

BEAUFORT RATING	WIND SPEED				GROUND CONDITIONS
	m/s	km/h	ft/s	mph	
3	3,4-5,4	12,25-19,4	11.5-17.75	7.5-12.0	Papers and thin branches move, flags wave.
4	5,4-8,0	19,4-28,8	17.75-26.25	12.0-18	Dust is raised, paper whirls up, and small branches sway.
5	8,0-10,8	28,8-38,9	26.25-35.5	18-24.25	Shrubs with leaves start swaying. Wave crests are apparent in ponds or swamps.
6	10,8-13,9	38,9-50,0	35.5-45.5	24.5-31	Tree branches move. Power lines whistle. It is difficult to open an umbrella.
7	13,9-17,2	50,0-61,9	45.5-56.5	31.-38.5	Whole trees sway. It is difficult to walk against the wind.

LIFT OVERLOAD ALARM

If a load equivalent to 90% of safe working load is lifted a fault code "03" will be displayed on the digital display on the platform control box. If a load which is greater than the safe working load is present in the basket all machine functions will cease to operate and an acoustic warning will sound. In order to return to normal operation a load equal to or less than the safe working load must be present in the basket and the power must be re-cycled, power can be re-cycled by pushing the emergency stop button and releasing it again.



Never operate the machine with a platform load greater than the rated capacity.

CONTROLS AND INDICATORS

Figure 2: Controls and Indicators

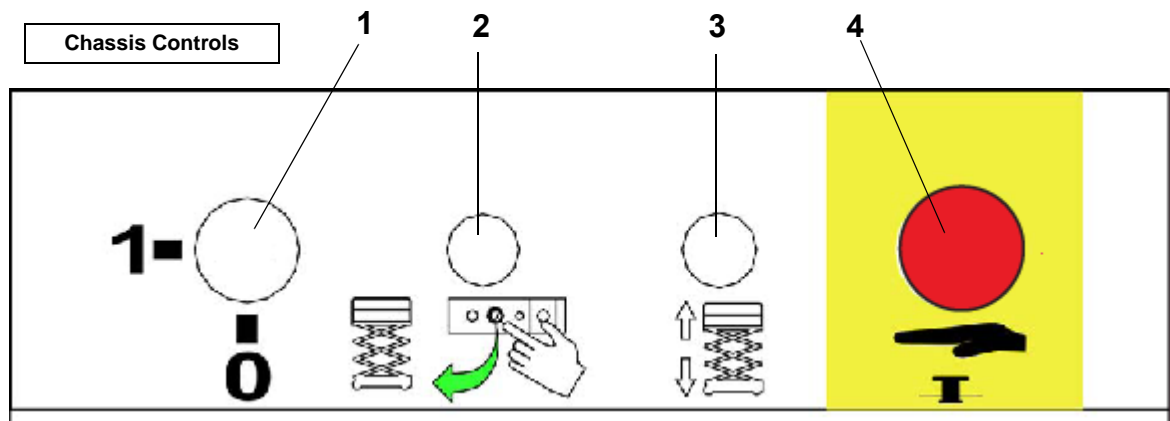
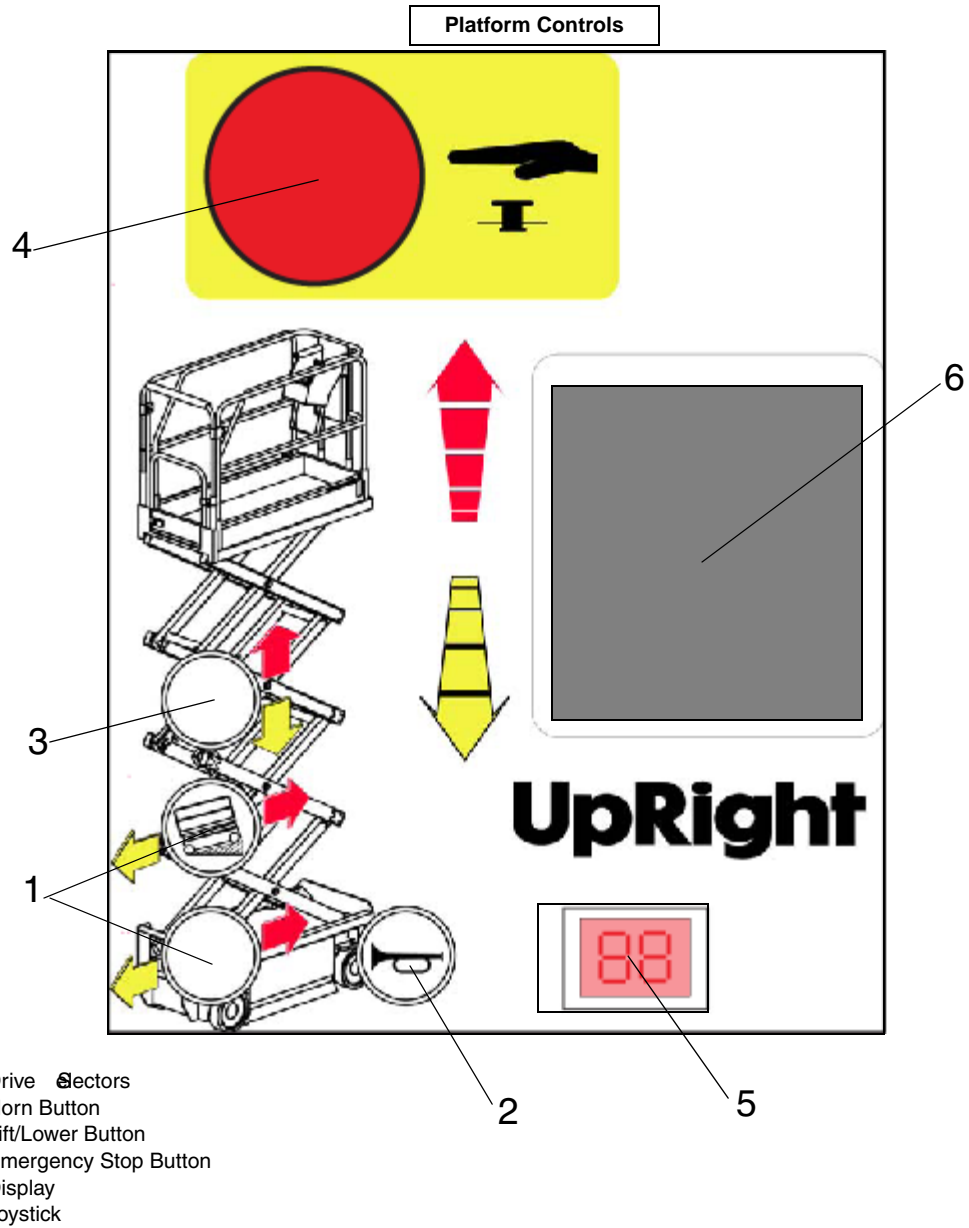

1. Keyswitch
2. Enable Button
3. Toggle Switch (Up & Down)
4. Emergency Stop Switch

PRE-OPERATION SAFETY INSPECTION

NOTE: Carefully read, understand and follow all safety rules, operating instructions, labels and National Safety Instructions/Requirements. Perform the following steps each day before use.

1. Open modules and inspect for damage, fluid leaks or missing parts.
2. Check the level of the hydraulic fluid with the platform fully lowered. The hydraulic reservoir is located in the Control Module Door. The fluid level must be between the MIN and MAX lines. Add hydraulic fluid if necessary.
3. Check that fluid level in the batteries is correct.
4. Verify that batteries are charged.
5. Check that A.C. extension cord has been disconnected from the plug in the rear of the machine.
6. Check that all guardrails are in place and all fasteners are properly tightened.
7. Inspect the machine thoroughly for cracked welds and structural damage, loose or missing hardware, hydraulic leaks, damaged control cable, loose wire connections and wheel bolts.

Figure 3: Hydraulic Tank

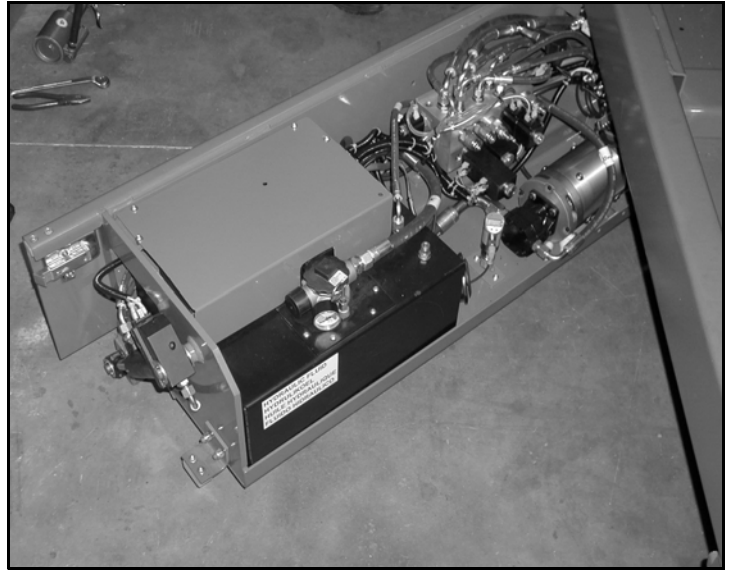

SYSTEM FUNCTION INSPECTION

Refer to Figure 2 for the locations of various controls and indicators.

! WARNING !

STAND CLEAR of the work platform while performing the following checks.

Before operating the work platform, survey the work area for surface hazards such as holes, drop-offs, bumps and debris.

*Check in **ALL** directions, including above the work platform, for obstructions and electrical conductors.*

Protect the control console cable from possible damage while performing checks.

1. Move the machine, if necessary, to an unobstructed area to allow for full elevation.
2. Pull Chassis Emergency Stop Switch to the ON position.
3. Pull Platform Emergency Stop Switch to the ON position.
4. Turn and hold the Chassis Key Switch to the ON position. Push the Chassis Lift/Lower Switch to the UP position and raise the platform approximately 2,1 m (7 feet). **BLOCK THE ELEVATING ASSEMBLY AS DESCRIBED ON PAGE 9.**
5. Visually inspect the elevating assembly, lift cylinder, cables, and hoses for cracked welds and structural damage, loose hardware, hydraulic leaks, loose wire connections, and erratic operation. Check for missing or loose parts.
6. Verify that the Depression Mechanism Supports have rotated into position under the machine. **REMOVE THE SCISSOR BRACE AS DESCRIBED ON page 13.**
7. Push the Chassis Lift/Lower Switch to the UP position and fully elevate the platform.
8. Partially lower the platform by pushing Chassis Lift/Lower Switch to LOWER, and check for proper operation of the audible lowering alarm.
9. Open the Emergency Lowering Valve (see Figure 5) by pulling the knob out to check for proper operation. When the platform is lowered, release the knob.
10. Push the Chassis Emergency Stop Switch to check for proper operation. All machine functions should be disabled. Pull out the Chassis Emergency Stop Switch to resume.
11. Check that the route is clear of obstacles (persons, obstructions, holes, and drop-offs, bumps and debris), is level, and is capable of supporting the wheel loads.
12. Mount the platform and properly close the entrance.
13. Mount the platform and select DRIVE mode.

NOTE: Use both HI and LOW drive (if applicable) when performing the following step.

14. While engaging the Interlock Switch, move the Control Handle to FORWARD, then REVERSE, to check for speed control.
15. Push the Steering Switch RIGHT, then LEFT, to check for steering control.
16. Select LIFT mode. Grasp the Control Handle, engaging the Interlock Switch, and push it forward to check platform lift controls. Raise the platform to full elevation.
17. Pull back on the Control Handle. The platform should descend and the audible lowering alarm should sound.
18. Push the Platform Emergency Stop Switch to check for proper operation. All machine functions should be disabled. Pull out the Platform Emergency Stop Switch to resume.

OPERATION

Before operating the work platform, ensure that the Pre-Operation Safety Inspection has been completed and that any deficiencies have been corrected. **Never operate a damaged or malfunctioning machine.** The operator must be thoroughly trained on this machine.

PLATFORM EXTENSION

1. Mount the platform and properly close the entrance.
2. Depress the foot lever located at the rear of the platform extension. Push the platform extension forward until the pin engages the front stop.
3. To retract the platform extension, depress the foot lever and pull the platform extension toward the rear of the machine until the pin engages the rear stop.

Figure 4: Platform Extension

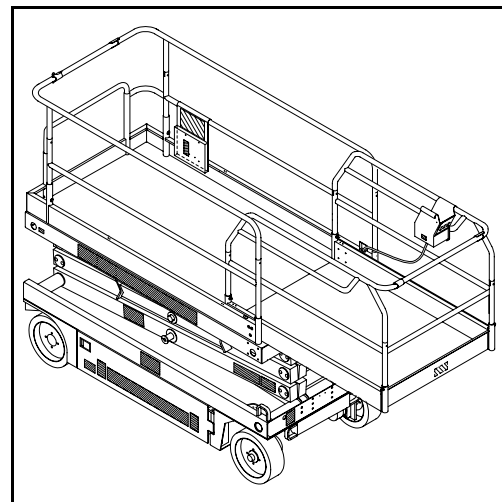

TRAVEL WITH THE PLATFORM LOWERED

1. Check that the route is clear of obstacles (persons, obstructions, holes, drop-offs, bumps, and debris), is level, and is capable of supporting the wheel loads.
2. Verify that the Chassis Key Switch is turned to ON and the Chassis Emergency Stop Switch is ON (pulled out).
3. Mount the platform and properly close the entrance.
4. Check clearances above, below, and to the sides of platform.
5. Pull the Platform Emergency Stop Switch out to the ON position.
6. Select DRIVE mode.

NOTE: Choose between standard drive and extra torque depending on the gradient.

7. Engage the Interlock Switch and move the Control Handle to FORWARD or REVERSE to travel in the desired direction. The speed of the machine will vary depending on how far from centre the Control Handle is moved.

STEERING

1. Turn the Drive/Lift Switch to DRIVE.
2. While engaging the Interlock Switch, push the Steering Switch to RIGHT or LEFT to turn the wheels in the desired direction. Observe the tires while manoeuvring the work platform to ensure proper direction.

NOTE: Steering is not self-centring. Wheels must be returned to the straight ahead position by operating the Steering Switch.

ELEVATING THE PLATFORM

1. Select a firm, level surface.
2. Select LIFT mode.
3. While engaging the Interlock Switch, push the Control Handle forward.
4. If the machine is not level the tilt alarm will sound and the machine will not lift or drive. **If the tilt alarm sounds the platform must be lowered and the machine moved to a firm level surface before attempting to re-elevate the platform.**

NOTE: Depression Mechanism supports will deploy automatically as the platform elevates and will retract after the platform has been lowered completely and has been driven.

TRAVEL WITH THE PLATFORM ELEVATED

NOTE: The machine will travel at reduced speed when the platform is elevated.

1. Check that the route is clear of obstacles (persons, obstructions, holes, drop-offs, bumps, and debris), is level, and is capable of supporting the wheel loads.
2. Check clearances above, below, and to the sides of platform.
3. Select DRIVE mode.
4. Engage the Interlock Switch and move the Control Handle to FORWARD or REVERSE to travel in the desired direction. The speed of the machine will vary depending on how far from centre the Control Handle is moved.
5. If the machine is not level the tilt alarm will sound and the machine will not lift or drive. **If the tilt alarm sounds the platform must be lowered and the machine moved to a firm, level surface before attempting to re-elevate the platform.**

LOWERING THE PLATFORM

1. Select LIFT mode.
2. Check around the base of the platform to ensure that no one is in contact with the machine. Engage the Interlock Switch and pull back on the Control Handle to lower the platform.
3. The platform will stop when it reaches the PPE cutout height. Inspect around the machine to ensure no one is in contact with the machine. After a four-second time delay, lower the platform as in step 2.

EMERGENCY LOWERING

⚠ WARNING ⚠

If the platform should fail to lower, NEVER climb down the elevating assembly.

Stand clear of the elevating assembly while operating the Emergency Lowering Valve Knob.

X26

The Emergency Lowering Valve for the X26 is located at the rear of the machine, above the charger.

1. Open the Emergency Lowering Valve by pulling and holding the knob.
2. To close, release the knob. The platform will not elevate if the Emergency Lowering Valve is open.

X32

The emergency lowering control switch is located at the rear of the machine.

1. Open the emergency lowering valve by pushing down on the toggle switch and holding it.
2. Once the platform is fully lowered, release the toggle switch to close the valve. The platform will not elevate if the Emergency Lowering Valve is open.

Figure 5: Emergency Lowering Valve

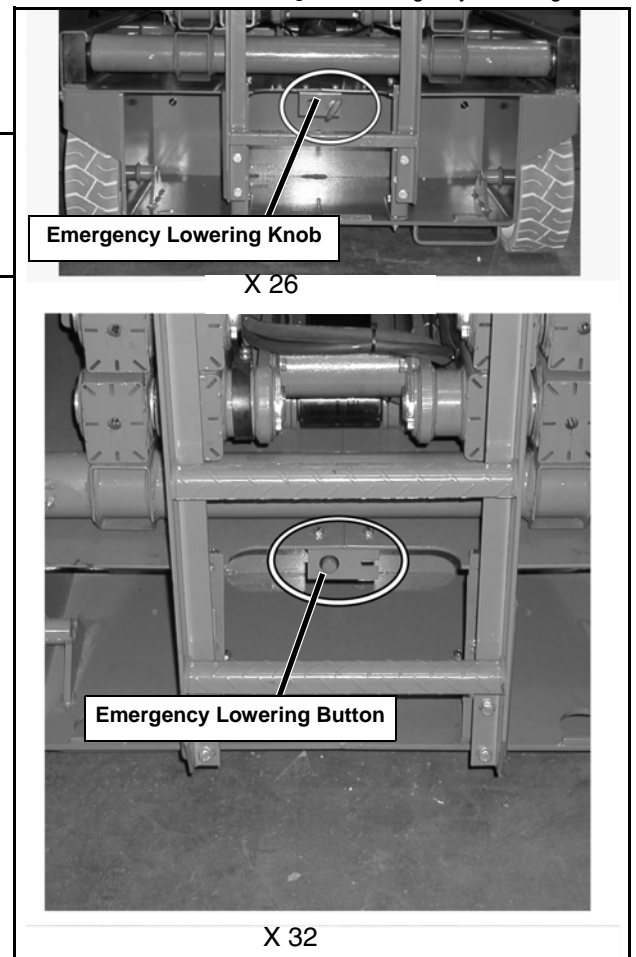

LOWER THE GUARDRAILS, X26

This procedure applies only to the X26 model for the purpose of passing through a standard double doorway. **Guardrails must be returned to proper position before using the machine.**

LOWERING PROCEDURE

1. Ensure that the slide-out deck extension is fully retracted and the deck pin is locked. Place the Platform Controls on the floor of the platform.
2. Remove and retain the set screws from the side guardrails and the slide-out deck guardrails.
3. Lower the slide-out deck guardrail completely.
4. Lower the rear guardrail until it rests on the stop screws.
5. Lower the side guardrails completely.
6. Raise the rear guardrail until the retaining pins engage. Remove and retain the stop screws and nuts from the rear guardrail.
7. Pull the two retaining pins and lower the rear guardrail completely.

RAISING PROCEDURE

1. Raise the rear guardrail until the retaining pins engage.
2. Install the stop screws and nuts on the rear guardrail and torque to 42 N-m (31 ft. lbs).
3. Pull the two retaining pins and lower the rear guardrail until it rests on the stop screws.
4. Raise the side guardrails until the tops are level with the rear guardrail.
 - Install the set screws
5. Raise the slide-out deck guardrail until the top is level with the side guardrails.
 - Install the set screws
6. Hang the controller on the slide-out deck guardrail.
7. Torque all set screws to 42 N-m (31 ft. lbs).

⚠ WARNING ⚠

Before operating machine, guardrails must be securely fastened in their proper position.

FOLD DOWN GUARDRAILS, X32

This procedure applies only to the X32 model for the purpose of passing through a standard double doorway. **Guardrails must be returned to proper position before using the machine.**

FOLD DOWN PROCEDURE

1. Unhook the controller from the side guardrail and place it on the floor of the platform.
2. Pull the retaining pin on the front guardrail and rotate inwards.
3. Pull the retaining pin on the rear guardrail and rotate inwards.
4. Starting with the slide-out deck guardrails and then the outer guardrails, lift up on each guardrail and fold inward.

ERECTION PROCEDURE

1. Starting with the outer guardrails and then the slide-out deck guardrails, raise each guardrail and drop it down, securing it in the vertical position.
2. Rotate the front and rear upper guardrails outward and secure them to the opposite side guardrails, using the retaining pins.
3. Hang the controller on the side guardrail.

TOWING OR WINCHING

Perform the following only when the machine will not operate under its own power and it is necessary to move the machine or when winching onto a transport vehicle (see “Transporting the Work Platform” on page 11).

CAUTION

DO NOT tow or winch the machine faster than 0,3 m/s (1 ft./s). Faster speeds will damage drive components and void the warranty.

⚠ WARNING ⚠

Never tow faster than 0,3 m/sec. (1 ft./sec.).

Never operate the work platform with the parking brakes released. Serious injury or damage could result.

AFTER USE EACH DAY

1. Ensure that the platform is fully lowered.
2. Park the machine on a firm level surface, preferably under cover, secure against vandals, children and unauthorized operation.
3. Turn the Chassis Key Switch to OFF and remove the key to prevent unauthorized operation.

HOOR METER

To access the hour meter function perform the following steps.

1. Climb into the basket (with the machine powered up)
2. Push the platform emergency stop button.
3. Hold down the following buttons, Jib and Upper Boom Lift.
4. While holding the buttons twist the emergency stop button to return power to the machine.
5. “hr” will now be displayed on the read-out, Pressing the right turn button will scroll through the accumulated hours two digits at a time. For example, if pressing the right turn button once displays “20”, pressing it a 2nd time displays “58”, and pressing it a 3rd time displays “hr”, the elapsed time of operation is 2058 hours.

TRANSPORTING THE WORK PLATFORM

PREPARATION FOR SHIPMENT

1. Fully lower the platform.
2. Disconnect the battery negative (-) lead from the battery terminal.
3. Band the controller to the front guardrail.
4. Band the elevating linkage to the frame.

Figure 6: Secure Crane Straps

LIFTING BY CRANE

1. Secure straps to chassis tie down/lifting lugs only.
2. Place the platform onto the transport vehicle in transport position.
3. Chock the wheels.
4. Secure the work platform to the transport vehicle with chains or straps of adequate load capacity attached to the chassis tie down/lifting lugs.

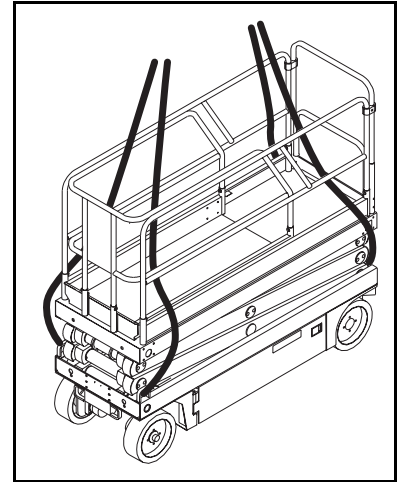

BY FORKLIFT



Forklifting is for transport only.

See specifications for weight of work platform and be certain that forklift is of adequate capacity to lift the work platform.

Forklift from the rear of the machine using the forklift pockets provided. If necessary, the machine may be forklifted from the side by lifting under the Chassis Modules.

Figure 7: Transporting the Work Platform

DRIVING OR WINCHING ONTO A TRUCK OR TRAILER

NOTE: Do not winch faster than 0,3 m/s (1 ft/s).

1. Move the machine onto the truck or trailer;
 - A. To **Drive** the machine onto the transport vehicle:
 - a. Move the work platform up the ramp and into transport position.
 - b. Set the wheels straight and turn off the machine.
 - c. Chock the wheels.
 - B. To **Winch** the machine onto the transport vehicle:
 - a. Move the work platform up to the ramp.
 - b. Attach the winch cable to the tie down/lifting lugs.
 - c. Release the parking brakes (refer to "Towing or Winching" on page 11).
 - d. Winch the platform into transport position
 - e. Chock the wheels.
2. Secure the work platform to the transport vehicle with chains or straps of adequate load capacity attached to the chassis tie down/lifting lugs.

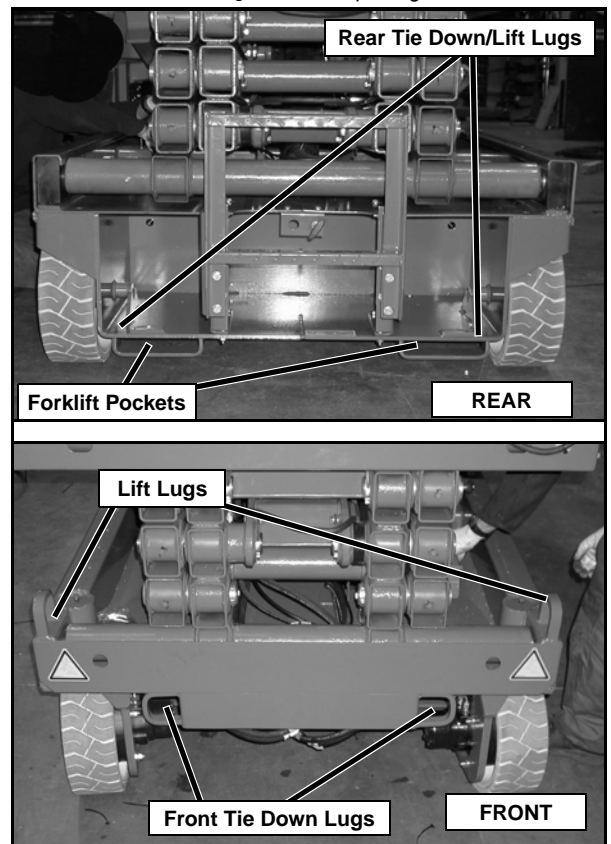

CAUTION

Over tightening of the chains or straps attached to the Tie Down/Lifting Lugs may result in damage to work platform.

MAINTENANCE

⚠ WARNING ⚠

Never perform service while the platform is elevated without first blocking the elevating assembly.
DO NOT stand in the elevating assembly area while deploying or storing the brace.

BLOCKING THE ELEVATING ASSEMBLY

SCISSOR BRACE INSTALLATION

1. Park the work platform on a firm, level surface.
2. Pull Chassis EMERGENCY STOP Switch to the ON position.
3. Pull Platform EMERGENCY STOP Switch to the ON position.
4. Turn and hold the Chassis Key Switch to CHASSIS.
5. Push the Chassis Lift/Lower Switch to LIFT to elevate the platform until the Scissor Brace can be rotated to the vertical position.
6. X26 – From the rear of the machine, lift the Scissor Brace from its stowed position. Rotate upward and outward, then down until it is hanging vertically below its attachment point.
7. X32 – From the left side of the machine, pull the locking pin securing the brace. Rotate the Scissor Brace counter clockwise until it is in the vertical position.
8. Lower the platform by pushing the Chassis Lift/Lower Switch to LOWER and gradually lower the platform until the Scissor Brace is supporting the platform.

SCISSOR BRACE STOWAGE

1. Using the Chassis Controls, gradually elevate the platform until the Scissor Brace is clear.
2. X26 – Rotate the Scissor Brace outward and upward over its mounting point until it rests in the stowed position.
3. X32 – Rotate the Scissor Brace clockwise until the locking pin engages.
4. Lower the platform by pushing the Chassis Lift/Lower Switch to LOWER to completely lower the platform.

Figure 8: Scissor Brace

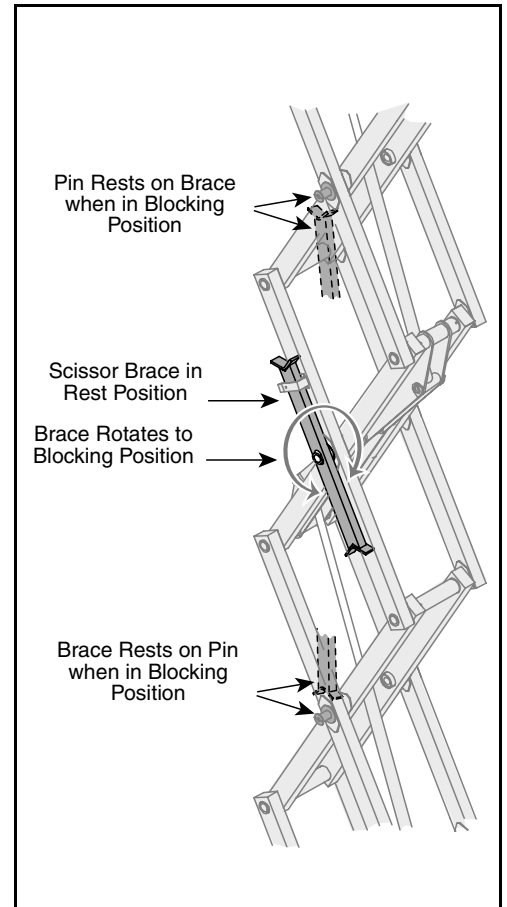

BATTERY MAINTENANCE

⚠ WARNING ⚠

Hazard of explosive gas mixture. Keep sparks, flame, and smoking material away from batteries.

Always wear safety glasses when working near batteries.

Battery fluid is highly corrosive. Thoroughly rinse away any spilled fluid with clean water.

*Always replace batteries with **UpRight** batteries or manufacturer approved replacements weighing 26,3 kg (58 lbs.) each.*

- Check the battery fluid level daily, especially if the work platform is being used in a warm, dry climate.
- If electrolyte level is lower than 10 mm ($\frac{3}{8}$ in.) above the plates add distilled water only. DO NOT use tap water with high mineral content, as it will shorten battery life.
- Keep the terminals and tops of the batteries clean.
- Refer to the Service Manual to extend battery life and for complete service instructions.

BATTERY CHARGING

Charge the batteries at the end of each work shift or sooner if the batteries have been discharged.

⚠ WARNING ⚠

Charge the batteries in a well ventilated area.

Do not charge the batteries when the work platform is near a source of sparks or flames.

Permanent damage to the batteries will result if the batteries are not immediately recharged after discharging.

Never leave the battery charger operating for more than two days.

Never disconnect the cables from the batteries when the charger is operating.

Keep the charger dry.

Figure 9: Battery Charger

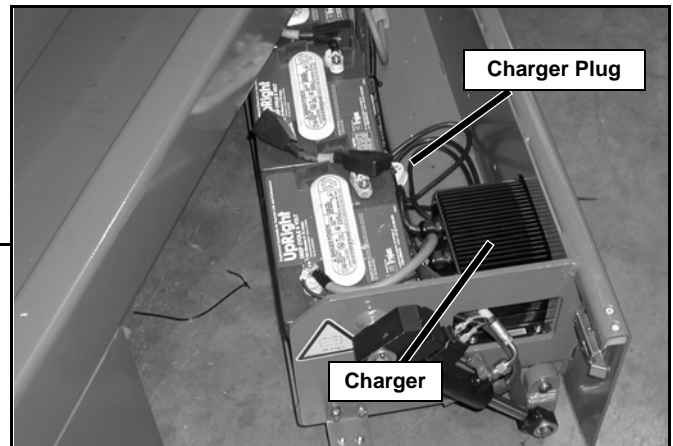

1. Check the battery fluid level. If the battery fluid level is lower than 10 mm ($\frac{3}{8}$ in.) above the plates add distilled water only.
2. Connect an appropriate extension cord to charger outlet plug in Left Module Door. Plug the extension cord into a properly grounded outlet of proper voltage and frequency.
3. The charger turns on automatically after a short delay. The LED charge indicator will illuminate. After completion of the charge cycle the LED will blink, indicating that the charger is in a continuing maintenance mode. DO NOT leave the charger plugged in for more than 48 hours, as permanent damage to the batteries may occur.

NOTE: The battery charger circuit must be used with a GFI (Ground Fault Interrupt) outlet.

NOTE: DO NOT operate the machine while the charger is plugged in.

INSPECTION AND MAINTENANCE SCHEDULE

The Complete Inspection consists of periodic visual and operational checks, along with periodic minor adjustments that assure proper performance. Daily inspection will prevent abnormal wear and prolong the life of all systems. The inspection and maintenance schedule should be performed at the specified intervals. Inspection and maintenance shall be performed by personnel who are trained and familiar with mechanical and electrical procedures.



*Before performing preventative maintenance, familiarize yourself with the operation of the machine.
Always block the elevating assembly whenever it is necessary to perform maintenance while the platform is elevated.*

The daily preventative maintenance checklist has been designed for machine service and maintenance. Please photocopy this page and use the checklist when inspecting the machine.

DAILY PREVENTATIVE MAINTENANCE CHECKLIST

MAINTENANCE TABLE KEY

Y = Yes/Acceptable

N = No/Not Acceptable

R = Repaired/Acceptable

PREVENTATIVE MAINTENANCE REPORT

Date: _____

Owner: _____

Model No: _____

Serial No: _____

Serviced By: _____

COMPONENT	INSPECTION OR SERVICES	Y	N	R
Battery	Check electrolyte level.			
	Check battery cable condition.			
Chassis	Check hoses for pinch or rubbing points.			
	Check welds for cracks.			
Control Cable	Check the exterior of the cable for pinching, binding or wear.			
Controller	Check switch operation.			
Drive Motors	Check for operation and leaks.			
Elevating Assembly	Inspect for structural cracks.			
Emergency Lowering System	Operate the emergency lowering valve and check for serviceability.			
Entire Unit	Check for and repair collision damage.			

COMPONENT	INSPECTION OR SERVICES	Y	N	R
Hydraulic Fluid	Check fluid level.			
Hydraulic Pump	Check for hose fitting leaks.			
Hydraulic System	Check for leaks.			
Labels	Check for peeling, missing, or unreadable labels & replace.			
Platform Deck and Rails	Check welds for cracks.			
Platform Deck and Rails	Check condition of deck.			
Tyres and Wheels	Check for damage.			

NOTES:

DECALS

These labels shall be present and in good condition before operating the work platform. Be sure to read, understand and follow these labels when operating the work platform.



101210-000

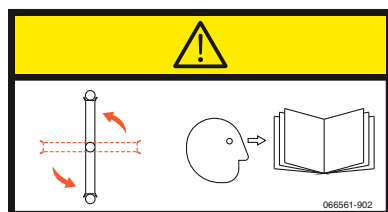

066561-902



501453-000

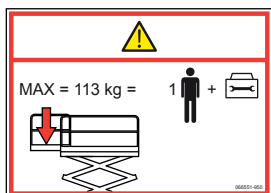

066551-950

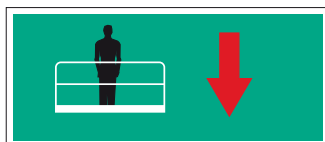

502480-000

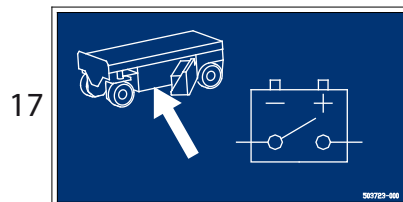

503723-000

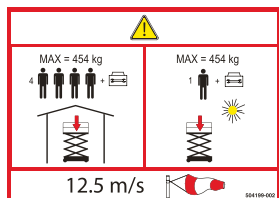

504199-002_x26



100076-901 Qty. 1

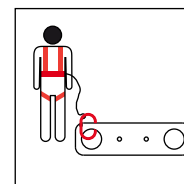

068635-001

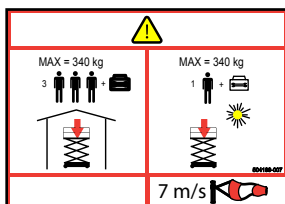

504199-007_x32



066556-900



067195-001



014222-903

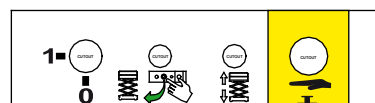

503721-000



503724-000



005221-000



508668-000

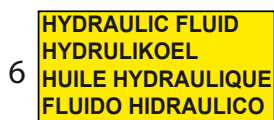

060197-001



062562-951



508667-000



100102-900

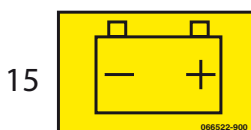

066522-900



508661-000

DECALS

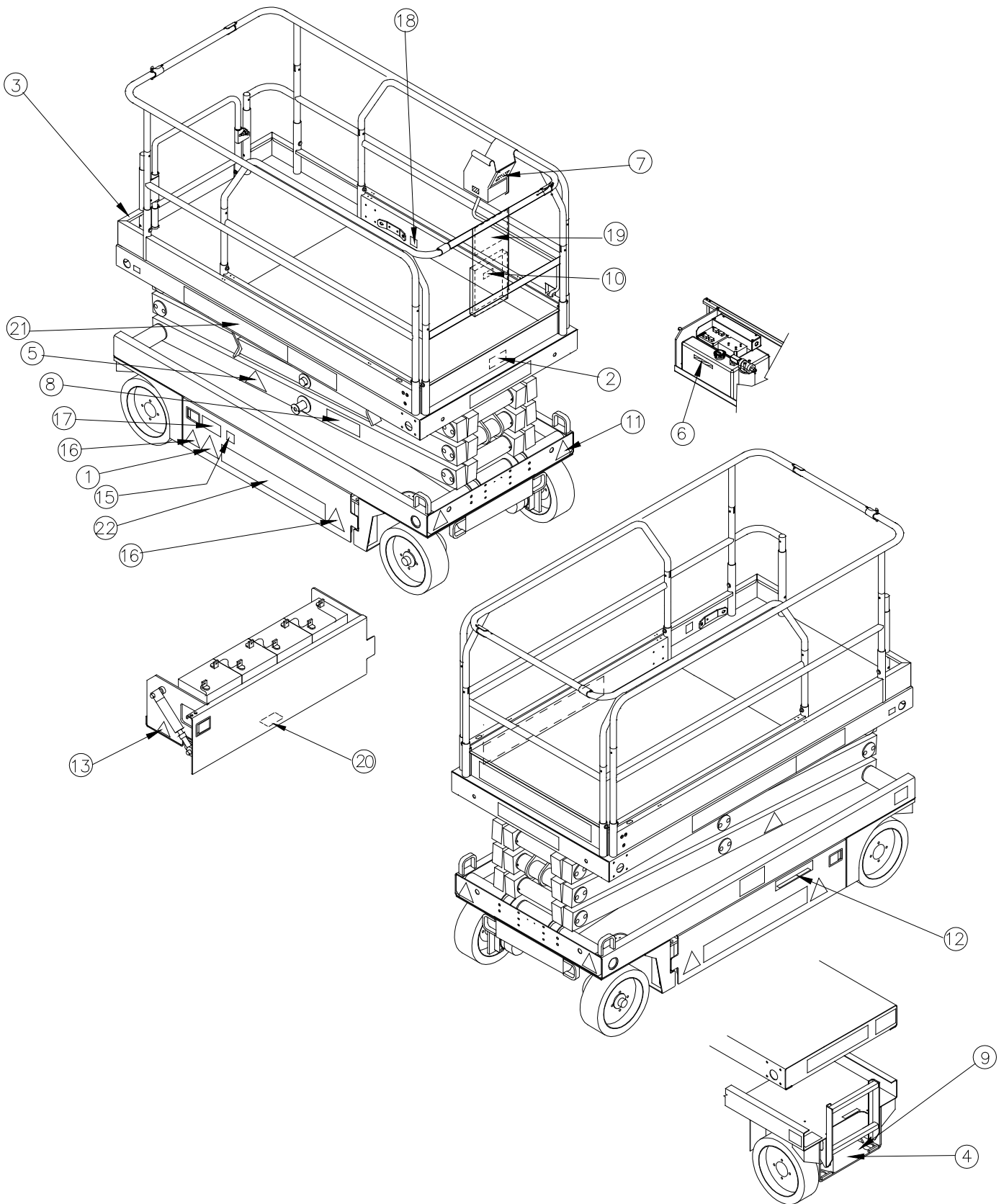

SPECIFICATIONS

ITEM	X26	X32
Platform Size w/ Extension	1,17 m x 2,21 m [44,25 pulg. x 87 pulg.]	1,17 m x 2,21 m [44 in. x 87 in.]
Max. Platform Capacity		
Standard	454 kg [1000 lb]	340 kg [750 lbs.]
on Extension	113 kg [250 lb]	113 kg [250 lbs.]
Max. No. of occupants		
Standard (total)	4 personas 1 personas en el exterior	3 people 1 personas en el exterior
on Extension	1 persona	1 person
MAX. Wind speed	12.5m/s	7 m/s
MAX. LATERAL FORCE	200N(Outdoors) & 400N (Indoors)	200N(Outdoors) & 400N (Indoors)
Height		
Working Height	9,93 m [32,58 pies]	11.6 m [38.1 ft.]
Max. Platform Height	7,93 m [26 pies]	9.75 m [32 ft.]
Min. Platform Height	1,09 m [43 pulg.]	1.22 m [48 in.]
Dimensions		
Weight	2153 kg [4747 lb]	2486 kg [5481 lbs.]
Overall Width	1,22 m [48 pulg.]	1.22 m [48 in.]
Overall Height	2,19 m [83,5 pulg.]	2.32 m [88.5 in.]
Overall Height, Rails Lowered	1,98 m [78 pulg.]	1.88 m [74 in.]
Overall Length, Extension In	2,35 m [92,5 pulg.]	2.35 m [92.5 in.]
Overall Length, Extension Out	3,26 m [128,5 pulg.]	3.26 m [128.5 in.]
Drivable Height	7,93 m [26 pies]	9.75 m [32 ft.]
Drive Speed		
Platform Lowered	0 to 3,2 km/h [0 to 2.0 mph]	
Platform Raised	0 to 1 km/h [0 to 0.62 mph]	
Energy Source	24 Volt Battery Pack (4-220 A Hour, 6 Volt Batteries, min. wt. 28.12 kg [62 lbs.] each)	
Motor	24 Volt 4 Horse Power DC Electric Motor	
System Voltage	24 Volt DC	
Battery Charger	25 A, 110/220 V AC	
Battery Duty Cycle	25% for 8 Hours	
Hydraulic Tank Capacity	15 L [4 US Gallons]	19 L [5 US Gallons]
Maximum Hydraulic Pressure	207 bar [3000 psi]	
Hydraulic Fluid		
Normal Temperature (>32° F [0° C])	ISO #46	
Low Temperature (<32° F [0° C])	ISO #32	
Extreme Temperature (<0° F [-17° C])	ISO #15	
Lift System	One Single Stage Lift Cylinder	Two Single Stage Lift Cylinders
Lift Speed	Raise, 45 sec./Lower 40 sec.	Raise, 65 sec./Lower 40 sec.
Control System	Proportional Control Handle with Interlock Switch, Rotary Drive/Lift Switch, and Red Mushroom EMERGENCY STOP Switch	
Drive System	Dual Front Wheel Hydraulic Motors	
Tires	381 mm [15 in.] Diameter Solid Rubber, non-marking	
Parking Brake	Dual Spring Applied, Hydraulic Release	
Turning Radius	203 mm [8 in.] Inside	
Maximum Gradeability	12° [22%]	12° [22%]
Wheel Base	1.9 m [74.75 in.]	
Guardrails	1.02 m [40 in.] High	
Noise Level		

*Specifications are subject to change without notice. Hot weather or heavy use may affect performance.

Refer to the Service Manual for complete parts and service information.

This machine meets or exceeds all applicable CE and GS machinery directive requirements.

SERVICE AND REPAIR

INTRODUCTION

This section contains instructions for the maintenance of the Work Platform.

Refer to the General Information section for information relevant to all **UpRight** work platforms.

Referring to the Operator Manual will aid in understanding the operation and function of the various components and systems of the work platform, and help in diagnosing and repair of the machine.

W A R N I N G

Be sure to read, understand and follow all information in the Operation Section of this manual before attempting to operate or perform service on any Work Platform.

D A N G E R

Never perform service on the work platform in the elevating assembly area while platform is elevated without first blocking the elevating assembly.

DO NOT stand in elevating assembly area while deploying or storing brace.

TABLE OF CONTENTS

3-1 Supporting Elevating Assembly	3-3
Installation	3-3
Removal	3-3
3-2 Preventative Maintenance	3-3
3-3 Preventative Maintenance Check List	3-4
3-4 Parts Location	3-5
3-5 General Lubrication	3-6
3-6 Batteries	3-7
Battery Replacement	3-7
Battery Maintenance	3-7
3-7 Safety Ancillary Equipment	3-8
Proximity Switch	3-8
Tilt Sensor	3-8
Emergency Lowering	3-9
3-8 Hydraulics	3-10
Hydraulic Oil Tank And Filter	3-10
Hydraulic Pump	3-11
Cylinder valve Assembly	3-11
Main Hydraulic Manifold	3-12
Setting Hydraulic Manifold Pressures	3-13
3-9 Cylinders	3-15
Depression Cylinder	3-15
Steering Cylinder	3-16
Lift Cylinder	3-17
3-10 Drive Motors	3-18
Removal	3-18
Installation	3-18
3-11 Controls	3-19
Platform Controls	3-19
Chassis Controls	3-20

3-1 SUPPORTING ELEVATING ASSEMBLY

⚠ WARNING ⚠

Never perform service on the work platform in the elevating assembly area while platform is elevated without first blocking the elevating assembly.

DO NOT stand in elevating assembly area while deploying or storing brace.

INSTALLATION

1. Park the Work Platform on firm level ground.
2. Verify Platform Emergency Stop Switch is **ON**.
3. Verify Platform Key Switch is **ON**.
4. Press the Enable button and push Chassis Lift/Lower toggle Switch to **UP** to elevate Platform.
5. Rotate the Scissor Brace into position.
6. Press the Enable button and push Chassis Lift/Lower toggle Switch to **DOWN** position and gradually lower Platform until the Scissor Assembly is supported by the brace.

REMOVAL

1. Press the Enable button and push Chassis Lift/Lower toggle Switch to **UP** to gradually raise Platform until the brace can be removed.
2. Rotate the brace to the stowed position.
3. Press the Enable button and push Chassis Lift/Lower toggle Switch to **DOWN** position and completely lower Platform

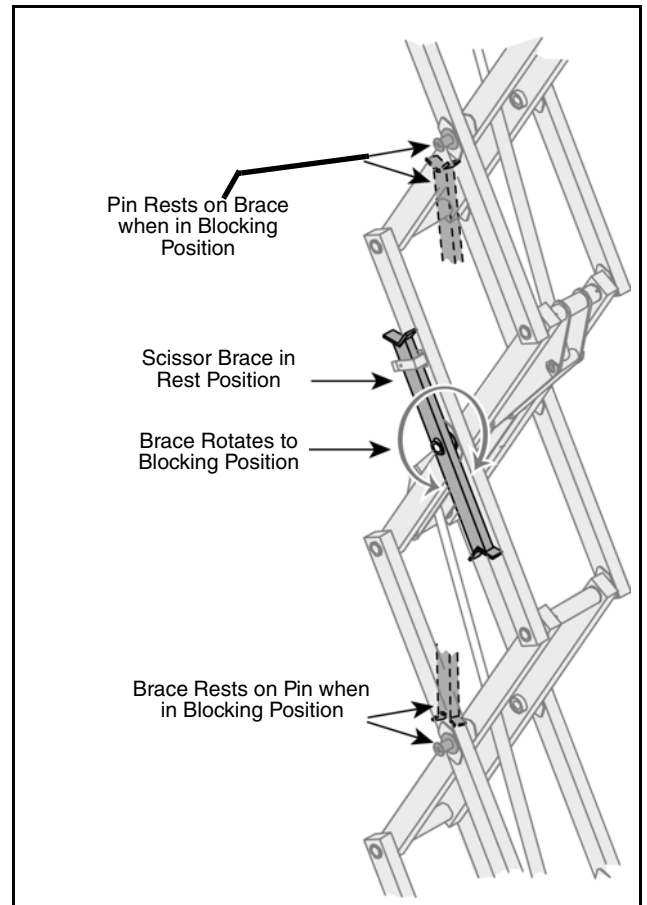

3-2 PREVENTATIVE MAINTENANCE

The complete inspection consists of periodic visual and operational checks, along with periodic minor adjustments to assure proper performance. Daily inspection will prevent abnormal wear and prolong the life of all systems. The inspection and maintenance schedule is to be performed at regular intervals. Inspection and maintenance shall be performed by personnel who are trained and familiar with mechanical and electrical procedures.

⚠ WARNING ⚠

Before performing preventative maintenance, familiarize yourself with the operation of the machine.

Always block the elevating assembly whenever it is necessary to enter the scissor assembly to perform maintenance while the platform is elevated.

The preventative maintenance table has been designed for machine service and maintenance repair. Please photocopy the following page and use the table as a checklist when inspecting the machine for service.

3-3 PREVENTATIVE MAINTENANCE CHECK LIST

PREVENTATIVE MAINTENANCE KEY

Interval

Daily=each shift or every day

50h/30d=every 50 hours or 30 days

250h/6m=every 250 hours or 6 months

1000h/2y=every 1000 hours or 2 years

Y=Yes/Acceptable

N=No/Not Acceptable

R=Repaired/Acceptable

PREVENTATIVE MAINTENANCE REPORT

Date: _____

Owner: _____

Model No: _____

Serial No: _____

Serviced By: _____

Service Interval: _____

COMPONENT	INSPECTION OR SERVICES	INTERVAL	Y	N	R
Battery System	Check electrolyte level	Daily			
	Check battery cable condition	Daily			
	Charge batteries	Daily			
	Check charger condition & operation	Daily			
	Check specific gravity	6m			
	Clean exterior	6m			
	Clean terminals	6m			
Hydraulic Oil *	Check oil level	Daily			
	Change Filter	6m			
	Drain and replace oil	2y			
Hydraulic System	Check for leaks	Daily			
	Check hose connections	30d			
	Check hoses for exterior wear	30d			
Drive Motors	Check for operation and leaks	Daily			
Emergency Down	Check procedure for Emergency Down	Daily			
Hydraulic Pump	Check for fitting leaks	Daily			
	Wipe clean	30d			
	Check for leaks at mating surfaces	30d			
	Check mounting bolts for proper torque	6m			
Controller	Check condition & operation	Daily			
Platform Deck & Rails	Check fasteners for proper torque	Daily			
	Check welds for cracks	Daily			
	Check condition of deck	Daily			
	Check entry way closure	Daily			

COMPONENT	INSPECTION OR SERVICES	INTERVAL	Y	N	R
Elevating Assembly	Inspect for external damage, dents, loose rivets or cracks	Daily			
Chassis	Check cables for pinch or rubbing points	Daily			
	Check welds for cracks	Daily			
	Check component mounting for proper torque	6m			
Lift Cylinder	Check for leaks	Daily			
	Check for proper torque	6m			
Entire Unit	Perform pre-operation inspection	Daily			
	Check for and repair collision damage	Daily			
	Lubricate	30d			
	Check fasteners for proper torque	6m			
Labels	Check for corrosion; remove and repaint	6m			
	Check for peeling, missing, or unreadable labels & replace	Daily			
Wheels	Check for loose components	Daily			
Steering System	Oil pivot pins	30d			
	Oil king pins	30d			
	Check steering cylinder for leaks	30d			
	Check Wheel Yoke Securing Bolt and Nut	30d			
	Check hardware & fittings for proper torque	6m			

* NOTE: Use ISO #46 during summer and ISO #32 during winter.

3-4 PARTS LOCATION

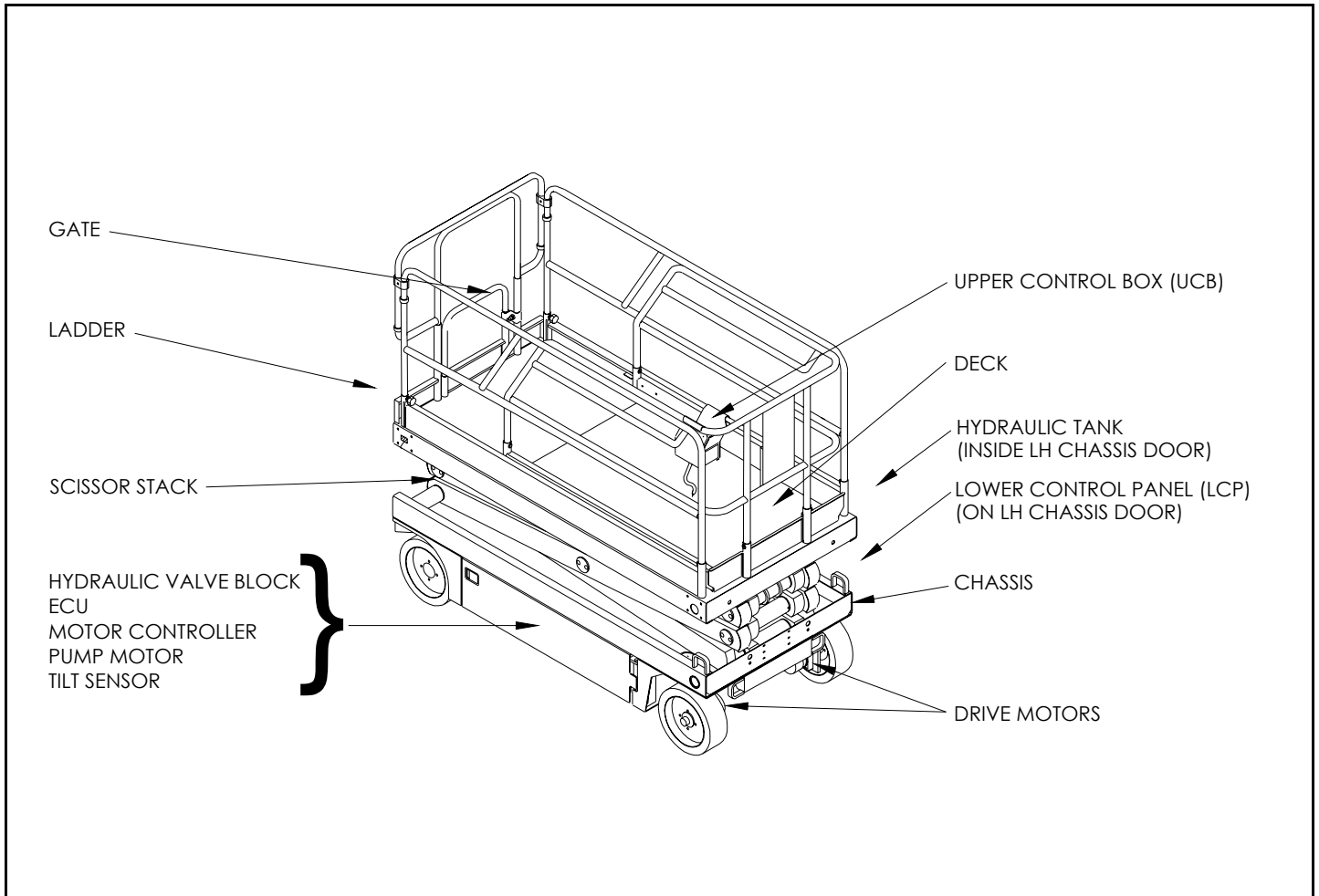

3-5 GENERAL LUBRICATION

- Apply grease to each grease fitting.

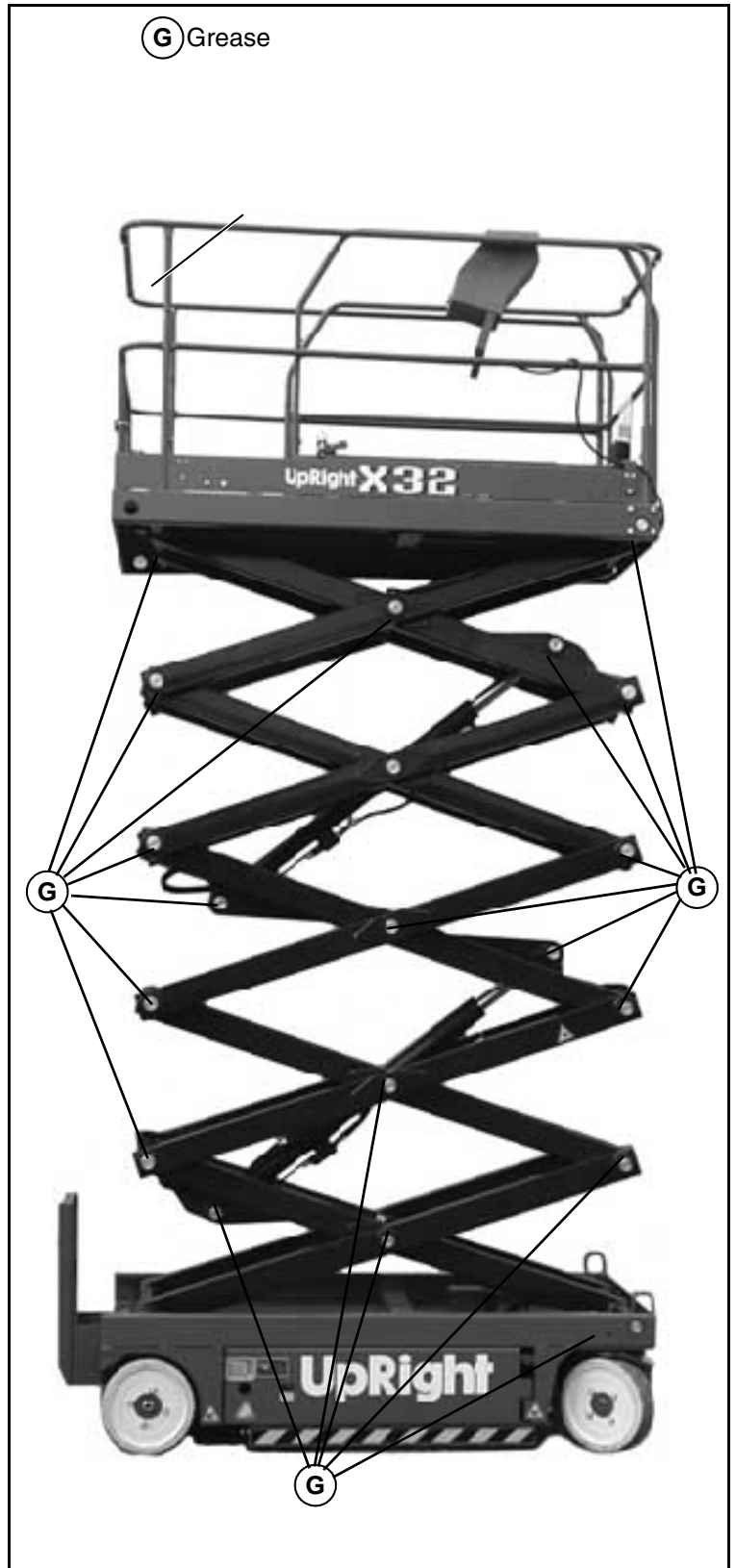

3-6 BATTERIES

Electrical Energy for the motor is supplied by four 6 volt batteries wired in series for 24 volts DC. Proper care and maintenance of the batteries and motor will ensure maximum performance from the work platform.

CAUTION

If battery water level is not maintained, batteries will not fully charge, creating a low discharge rate.

WARNING

Hazard of explosive gas mixture. Keep sparks, flame and smoking materials away from batteries.

Always wear safety glasses when working with batteries.

Battery fluid is highly corrosive. Thoroughly rinse away any spilled fluid with clean water.

*Always replace batteries with **UpRight** batteries or manufacturer approved replacements.*

Before disconnecting the battery negative (-) lead, make sure all switches are OFF. If ON, a spark will occur at the ground terminal which could cause an explosion if hydrogen gas or fuel vapors are present.

BATTERY REPLACEMENT

The batteries are located in a slide-out tray in the rear of the machine. There are four 6 volt batteries wired in series for 24 volts DC. Battery cables must be installed as shown in the Battery Cable Installation Diagram.

BATTERY MAINTENANCE

Refer to *Section 1: General Information* for complete battery maintenance instructions.

Refer to the *Operation Manual* included in this Service Manual for specific maintenance and charging instructions.

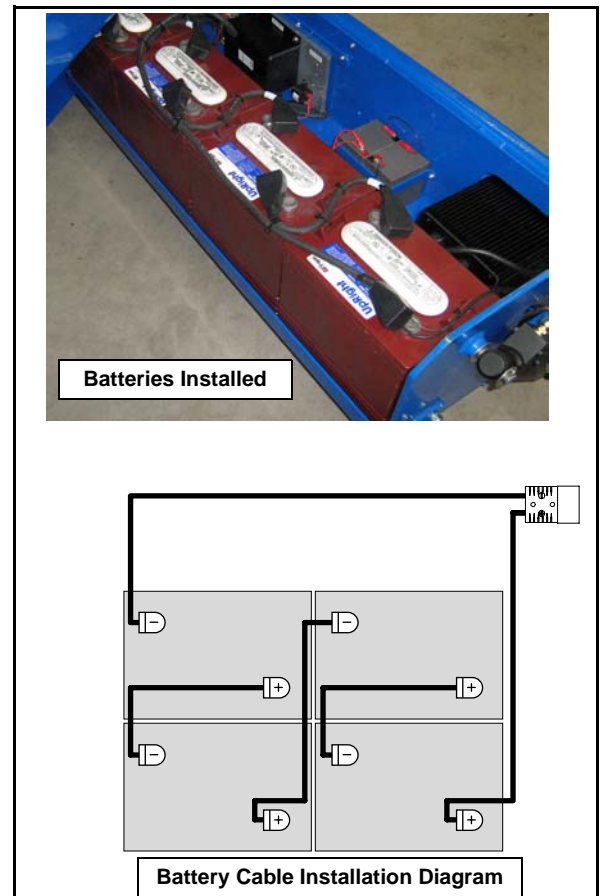

3-7 SAFETY ANCILLARY EQUIPMENT

PROXIMITY SWITCH

The Proximity Switch cuts power to the High Speed Drive when the platform is elevated.

The switch is located on the left side of the chassis at the rear of the machine.

No adjustment of the switch should be necessary.



LEVEL SENSOR

The Level Sensor is located on the chassis of the machine

These units are sealed and pre-set and require no recalibration or adjustment.



EMERGENCY LOWERING

⚠ WARNING ⚠

If the platform should fail to lower, NEVER climb down the elevating assembly.

Stand clear of the elevating assembly while operating the Emergency Lowering Valve Knob.

X26

The Emergency Lowering Valve for the X26 is located at the rear of the machine, above the charger.

1. Open the Emergency Lowering Valve by pulling and holding the knob.
2. To close, release the knob. The platform will not elevate if the Emergency Lowering Valve is open.

X32

The emergency lowering control switch is located at the rear of the machine.

1. Open the emergency lowering valve by pushing down on the toggle switch and holding it.

Once the platform is fully lowered, release the toggle switch to close the valve. The platform will not elevate if the Emergency Lowering Valve is open.

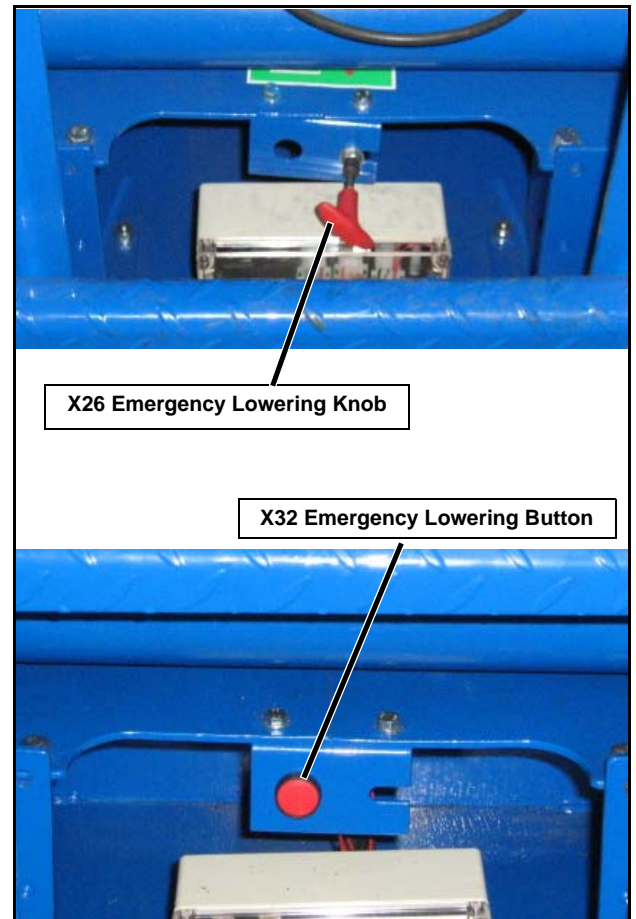

3-8 HYDRAULICS

HYDRAULIC OIL TANK AND FILTER

FLUID LEVEL

With the platform **fully lowered**, check the oil level through the side of the tank. The level should be between the “max” and “min” lines..

DO NOT fill above the MAX line on the tank.

DO NOT fill when the Platform is elevated.

OIL AND FILTER REPLACEMENT

1. Operate the work platform for 10-15 minutes to bring the hydraulic oil up to normal operating temperature.
2. Provide a suitable container to catch the drained oil. Hydraulic tank has a 12.9 liter (3.4 gal) capacity.
3. Remove the drain plug and allow all oil to drain. Dispose of hydraulic fluid properly- contact your local oil recycler.
4. Clean magnet on drain plug and reinstall.
5. Unscrew the filter (located beside valve block, easily accessed through the left module) from the filter assembly.
6. Apply a thin film of clean hydraulic oil to the gasket of the replacement filter.
7. Screw the replacement filter onto the filter head until the gasket makes contact, then rotate the filter 3/4 of a turn further.
8. Fill the hydraulic reservoir with hydraulic oil until the oil level is between the minimum and maximum lines on the tank. Do not fill above the maximum line on the tank. Hydraulic tank has a 12.9 liter (3.4 gal) capacity.
9. Operate all machine functions and recheck the fluid level. Add fluid if necessary.

NOTE : Drain plug underneath tank



Filler Cap

▲ CAUTION ▲

The hydraulic oil may be of sufficient temperature to cause burns. Wear safety gloves and safety glasses when handling hot oil.

HYDRAULIC PUMP

The Hydraulic Pump is located in the Power Module, and is mounted on the rear of the motor.

REMOVAL

NOTE: If the hydraulic tank has not been drained, suitable means for plugging the hoses should be provided to prevent excessive fluid loss.

1. Mark, disconnect and plug the hose assemblies.
2. Loosen the capscrews and remove the pump assembly from the motor.

INSTALLATION

1. Lubricate the pump shaft with general purpose grease and attach the pump to the motor with the capscrews.
2. Using a crisscross pattern, torque each capscrew a little at a time until all capscrews are torqued to 27N-m (**20 ft-lbs**).
3. Unplug and reconnect the hydraulic hoses.
4. Check the oil level in the hydraulic tank before operating the work platform.

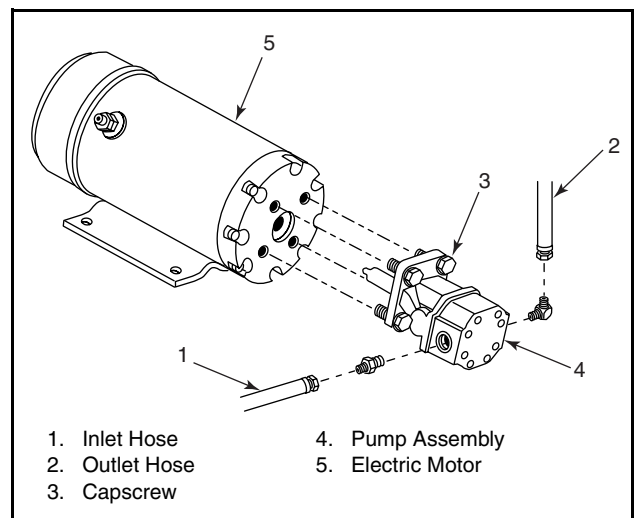

MAIN HYDRAULIC MANIFOLD

Though it is not necessary to remove the manifold to perform all maintenance procedures, a determination should be made prior to beginning as to whether or not the manifold should be removed before maintenance procedures begin.

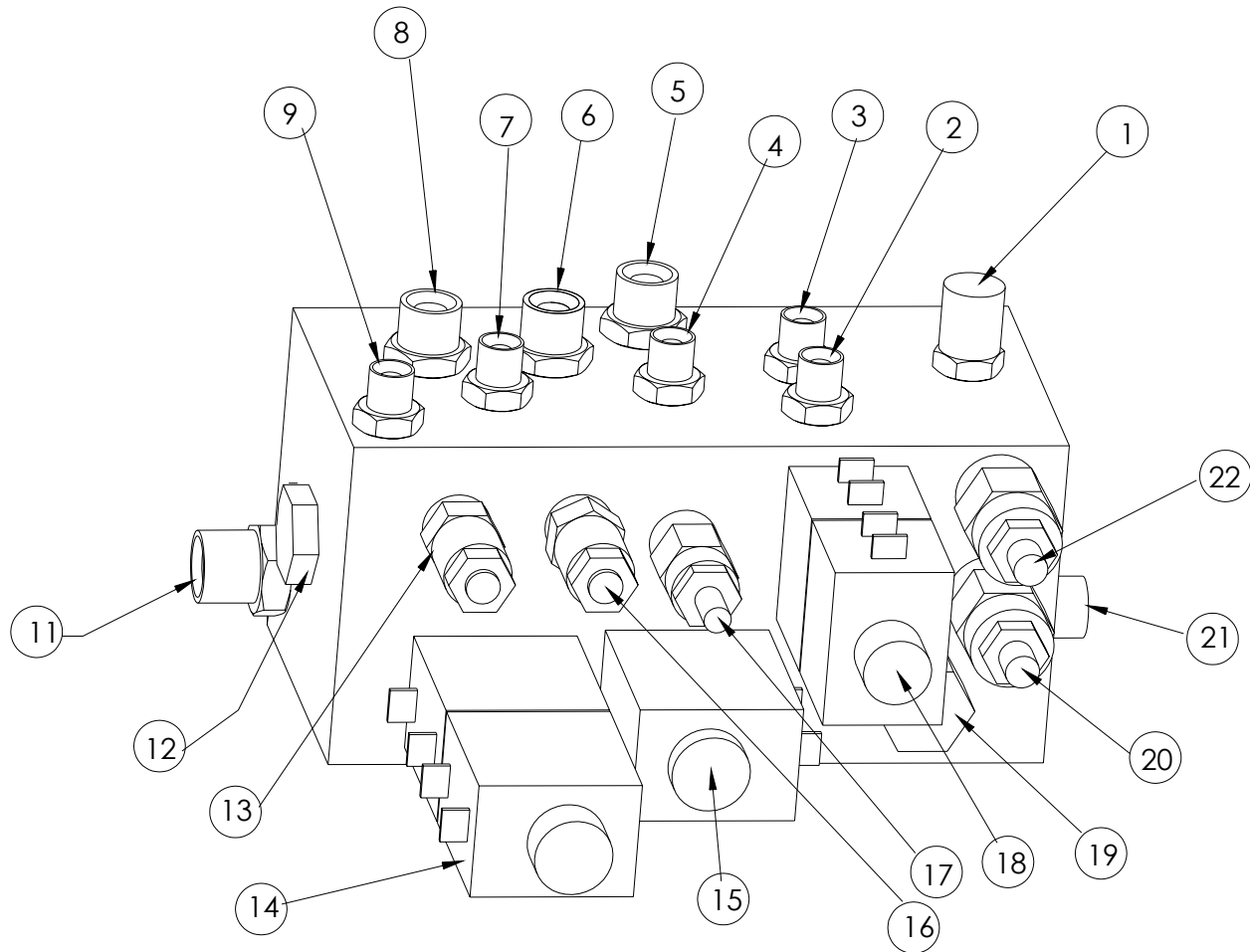

- | | |
|---|-------------------------------------|
| 1. TEST PORT (1/4") | 12. CHECK VALVE (POTHOLE) |
| 2. FITTING (1/4" - 1/4" MALE/MALE) | 13. CROSS LINE RELIEF VALVE (DRIVE) |
| 3. FITTING (1/4" - 1/4" MALE/MALE) | 14. SOLENOID VALVE (DRIVE) |
| 4. FITTING (1/4" - 1/4" MALE/MALE) | 15. SOLENOID VALVE (DRIVE/LIFT) |
| 5. FITTING (3/8" - 3/8" MALE/MALE) | 16. CROSS LINE RELIEF VALVE (DRIVE) |
| 6. FITTING (3/8" - 3/8" MALE/MALE) | 17. PRESSURE RELIEF (MAIN LIFT) |
| 7. FITTING (1/4" - 1/4" MALE/MALE WITH 1mm OROFICE) | 18. SOLENOID VALVE (STEERING) |
| 8. FITTING (3/8" - 3/8" MALE/MALE) | 19. FLOW RESTRICTOR (STEERING) |
| 9. FITTING (1/4" - 1/4" MALE/MALE) | 20. RELIEF VALVE (STEERING) |
| 10. - | 21. FITTING (3/8" - 3/8" MALE/MALE) |
| 11. FITTING (1/2" - 1/2" MALE/MALE) | 22. RELIEF VALVE (MAIN) |

SETTING HYDRAULIC MANIFOLD PRESSURES

⚠ WARNING ⚠

The hydraulic oil may be of sufficient temperature to cause burns. Wear safety gloves and safety glasses when handling hot oil.

The oil in the hydraulic system is under very high pressure which can easily cause severe cuts. Obtain medical assistance immediately if cut by hydraulic oil.

NOTE: Check the hydraulic pressures whenever the pump, manifold or relief valves have been serviced or replaced

MAIN RELIEF VALVE

1. Operate the hydraulic system 10 to 15 minutes to warm the oil.
2. Remove the cap or loosen the locknut on the Main Relief Valve.
3. Install a 0-207 bar (**0-3000 psi**) pressure gauge to the gauge port.
4. Turn the Chassis Keyswitch to CHASSIS and elevate the machine fully.
5. While holding the Chassis Lift Switch to the UP position, adjust the Main Relief Valve until the pressure gauge reads 165 bar (**2400 psi**).
6. Release the Chassis Lift Switch.
7. Replace the cap, or tighten the locknut on the Lift Relief Valve, and torque to 8N-m (**6 ft-lbs**).
8. Lower the platform.

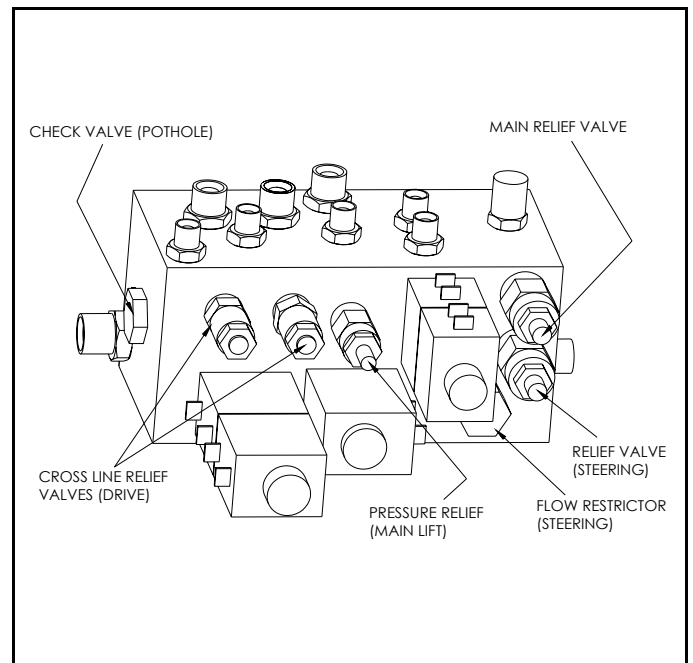

COUNTERBALANCE VALVES

1. Operate the work platform for 10-15 minutes to bring the hydraulic oil up to normal operating temperature.
2. Remove the gauge port cap and install the pressure gauge assembly.
3. Lift work platform and block front wheels off ground.
4. Loosen the locknuts on Counterbalance Valves.
5. With the machine fully powered up depress the **DRIVE** button on the upper control box, depress the interlock lever and slowly pull the control lever to **REVERSE** to drive the wheels.
6. Adjust the Forward Counterbalance Valve by turning the adjustment screw until the pressure gauge indicates 83 bar (**1200 psi**).
7. Slowly push the Control Lever to **FORWARD** to drive the wheels.
8. Adjust the Reverse Counterbalance Valve by turning the adjustment screw until the pressure gauge indicates 83 bar (**1200 psi**).
9. Check the settings by slowly moving the Control Lever **FORWARD**, then **REVERSE**, checking the gauge to ensure pressures are properly set. Re-adjust as needed.
10. Tighten locknuts on valves to 8N-m (**6 ft-lbs**). Remove blocks and lower work platform to ground.
11. Reconnect the red Control Cable wire to terminal #9.
12. Remove the gauge from the gauge port and re-install cap.
13. Check for proper operation of the drive system and brake.

STEERING RELIEF VALVES

1. Operate the work platform for 10-15 minutes to bring the hydraulic oil up to normal operating temperature.
2. Install gauge in the gauge port.
3. Loosen locknut or remove cover on the Steering Relief Valve and turn adjusting screw counter-clockwise two full turns.
4. While one person holds the Steering Switch to steer right or left, slowly turn the Steering Relief Valve adjusting screw clockwise to increase the pressure until the gauge reads 69 bar (**1000 psi**).
5. Tighten locknut or replace Steering Relief Valve cover and torque to 8N-m (**6 ft-lbs**).
6. Remove gauge and replace cap.

3-9 CYLINDERS

DEPRESSION CYLINDER

REMOVAL

1. Mark and disconnect the hose assemblies from the cylinder fittings and immediately cap the openings to prevent foreign material from entering.
2. Place a support under the depression guard.
3. Remove the circlips from the pivot pins.
4. Remove the pivot pins while supporting the cylinder.
5. Remove the cylinder.

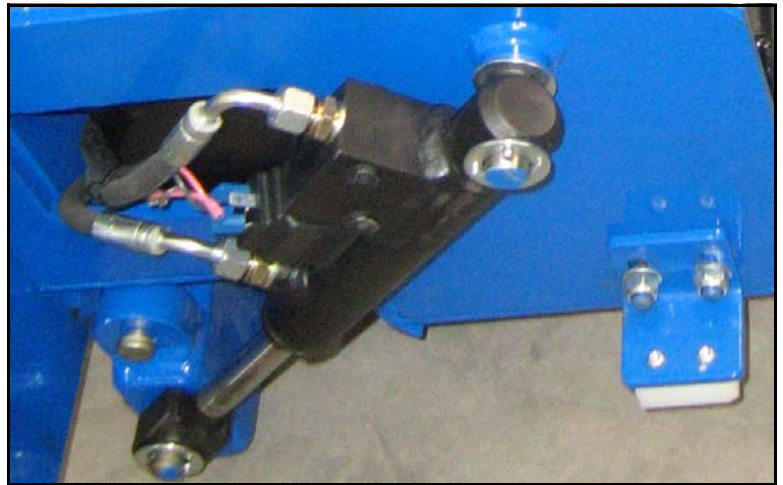

REPAIR

DISASSEMBLY

1. Unscrew the head cap from the barrel, removing the head cap, piston, and shaft assembly from the barrel tube.
2. Unscrew the piston.
3. Remove all rod wipers, U-cups, O-rings, and backup rings from the headcap, and discard.
4. Remove the piston ring and O-ring from the piston, and discard.

CLEANING AND INSPECTION

1. Wash all the metal parts in cleaning solvent and blow dry with filtered compressed air.
2. Inspect all the threaded components for stripped or damaged threads.
3. Check the inside surface of the cylinder barrel for scoring or excessive wear.
4. Check the piston and headcaps for scoring or excessive wear.
5. Inspect the surface of the shaft for scoring or excessive wear.

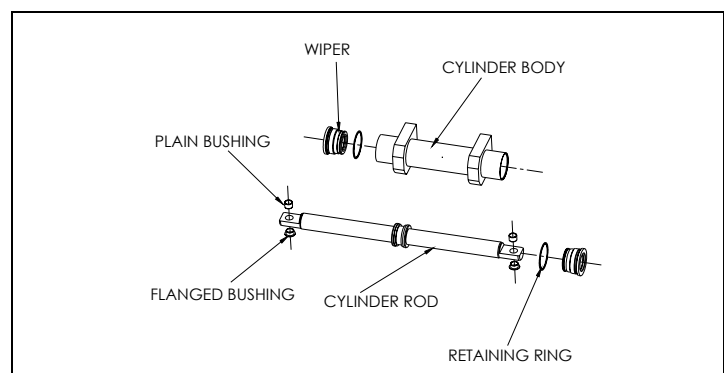

ASSEMBLY

1. Lubricate and install new rod wiper, U-cup, O-ring, and backup ring on the headcaps.
2. Install the headcap onto the shaft.
3. Install the new piston rings and O-ring on the piston. Re-install the piston.
4. Lubricate the piston seal with clean hydraulic fluid and install the shaft assembly in the cylinder barrel.
5. Install the head cap into the cylinder barrel, and tighten the head caps.

INSTALLATION

Installation is reverse of removal.

STEERING CYLINDER

REMOVAL

1. Mark and disconnect the hose assemblies from the cylinder fittings and immediately cap the openings to prevent foreign material from entering.
2. Remove the cotter pins from the pivot pins.
3. Remove the pivot pins while supporting the cylinder. Remove the cylinder.

REPAIR

DISASSEMBLY

1. Unscrew the head cap from the barrel, removing the head cap, piston, and shaft assembly from the barrel tube.
2. Unscrew the piston.
3. Remove all rod wipers, U-cups, O-rings, and backup rings from the headcap, and discard.
4. Remove the piston ring and O-ring from the piston, and discard.

Cleaning and Inspection

1. Wash all the metal parts in cleaning solvent and blow dry with filtered compressed air.
2. Inspect all the threaded components for stripped or damaged threads.
3. Check the inside surface of the cylinder barrel for scoring or excessive wear.
4. Check the piston and headcaps for scoring or excessive wear.
5. Inspect the surface of the shaft for scoring or excessive wear.

ASSEMBLY

1. Lubricate and install new rod wiper, U-cup, O-ring, and backup ring on the headcaps.
2. Install the headcap onto the shaft.
3. Install the new piston rings and O-ring on the piston. Re-install the piston.
4. Lubricate the piston seal with clean hydraulic fluid and install the shaft assembly in the cylinder barrel.

Install the head cap into the cylinder barrel, and tighten the head caps.

INSTALLATION

1. Position the cylinder assembly in the chassis and insert pivot pins and secure with new cotter pins.
2. Connect the hose assemblies to the fittings.
3. Operate the steering circuit several times throughout its entire range of travel to expel trapped air and check for leaks.

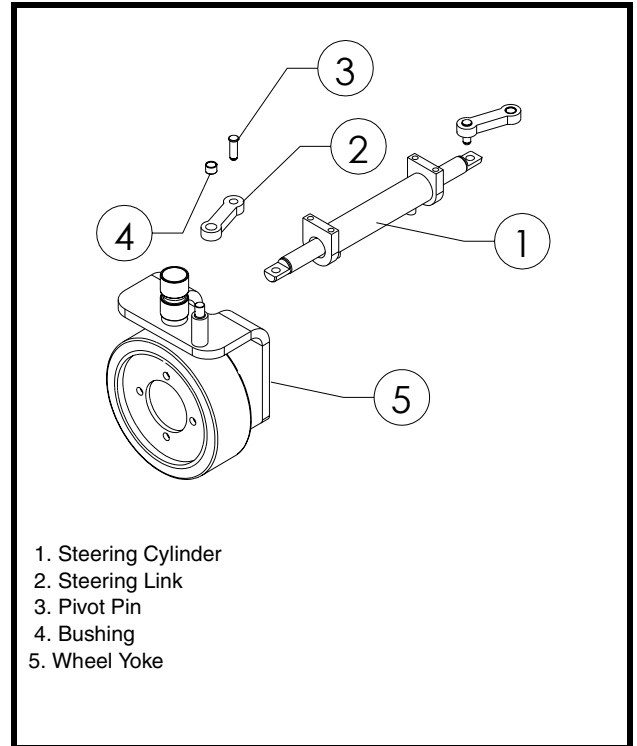

LIFT CYLINDER

REMOVAL

1. Provide a suitable container to catch the hydraulic fluid, then disconnect the hydraulic hoses. Immediately plug hoses to prevent foreign material from entering.
2. Remove emergency lowering valve cable and down valve wires from the emergency lowering/down valve.
3. Remove the cable bracket from the lift cylinder.
4. Remove capscrews and locknuts securing lift cylinder pivot pins.
5. Remove lower pivot pin and lower cylinder to rest on chassis.
6. Attach a suitable hoisting device and sling to the cylinder, and remove upper pivot pin.
7. Carefully remove cylinder.

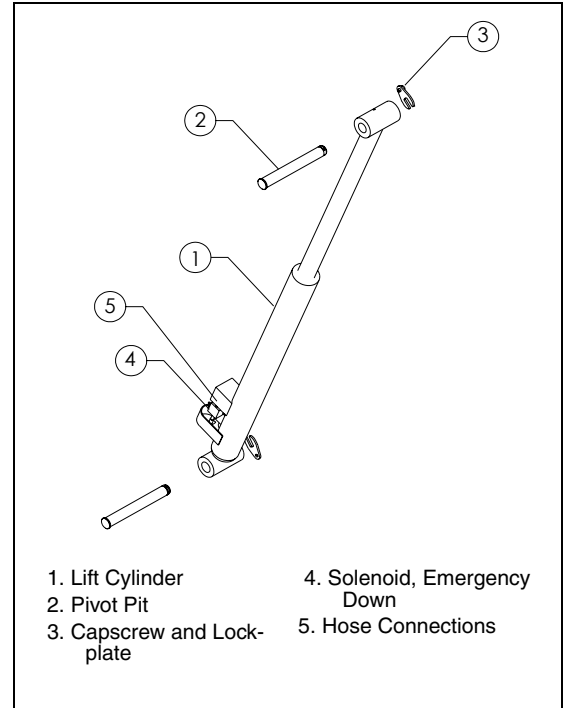

REPAIR

Refer to Pothole / Steering Cylinder Repair on Page 14 & 15.

INSTALLATION

1. Coat both pivot pins with anti-seize compound.
2. Attach a suitable hoisting device and sling to the cylinder. Carefully position cylinder in the elevating assembly, and install the upper pivot pin.
3. Install the capscrew and locknut.
4. Carefully lift the cylinder and align the lower mount, and install the pivot pin. Install the capscrew and locknut securing the pivot pin.
5. Install the cable bracket. Connect the emergency lowering valve cable and down valve wires.
6. Unplug hydraulic hoses and attach to the cylinder.
7. Replace hydraulic fluid removed from lift cylinder.
8. Test with weight at rated Platform load to check system operation. Check for leaks

3-10 DRIVE MOTORS

REMOVAL

1. Use a 1000Kg (**one ton**) capacity jack to raise the front of the machine. Position blocks under the machine to prevent the work platform from falling if the jack fails.
2. Block the rear wheels to prevent the machine from rolling.
3. Remove the cotter pin, nut, and washer.
4. Remove the wheel.

NOTE: Before disconnecting hoses, thoroughly clean off all outside dirt around fittings. (After disconnecting hoses and before removing from vehicle, IMMEDIATELY plug port holes.)

5. Tag, disconnect and plug the hose assemblies to prevent foreign material from entering.
6. Support the drive motor/wheel yoke assembly and remove the retaining ring at the top of the wheel yoke pivot. Remove the drive motor/wheel assembly from the machine.
7. Remove the locknuts, flat washers, capscrews and drive motor from the wheel yoke.

INSTALLATION

1. Position the drive motor in the wheel yoke and secure with cap screws, flat washers and locknuts.
2. Install the drive motor/wheel yoke assembly into the pivot bearing along with the lower thrust washer, thrust bushing, and retaining ring.
3. To ensure that the Wheel Yoke Assembly does not fall out of the Chassis when the vehicle is lifted off the ground fit a 3/8"UNC nut and a 1 1/4" long bolt, screw nut onto bolt until 6mm from bolt head.
Hand screw bolt into Chassis thread and tighten until bolt hits inner pin groove. Loosen bolt by a HALF turn of the bolt head. Whilst still holding bolt head with either ratchet socket or spanner turn down the nut till it hits Chassis outer casing and then tighten using a 9/16" spanner until nut is tight to outer material. This is to lock the bolt in position.
4. Align the steer pin with the hole in the steering link.
5. Remove the plugs from the hose assemblies and connect to the drive motor.
6. Install the shaft key, wheel, washer and slotted nut. Torque the locknut to 102 N-m (75 ft-lbs). Install a new cotter pin. DO NOT back-off the nut to install cotter pin.
7. Remove blocks, lower the jack and remove. Operate the drive system and check for leaks.

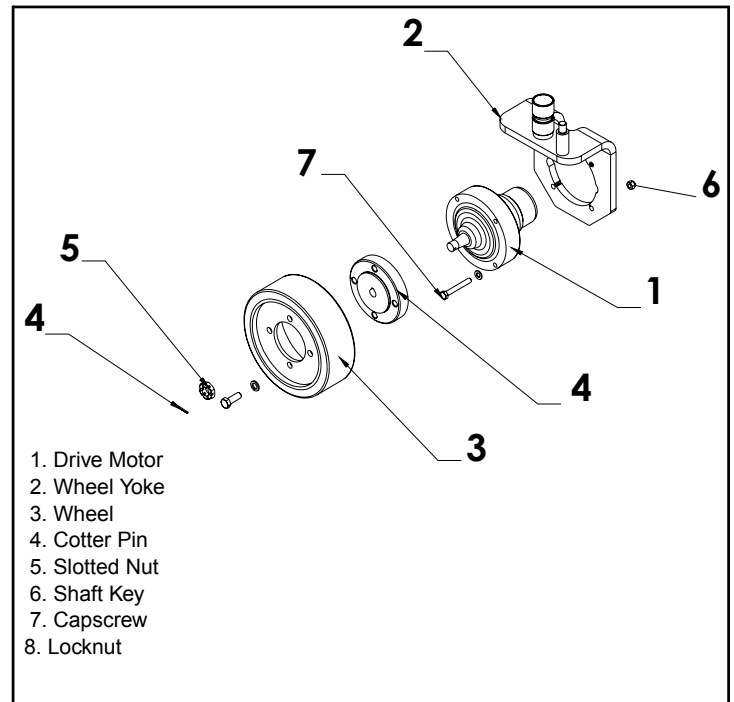

3-11 CONTROLS

PLATFORM CONTROLS

The Proportional Controller can be disassembled to replace defective switches. See the Parts Manual for replacement part numbers.

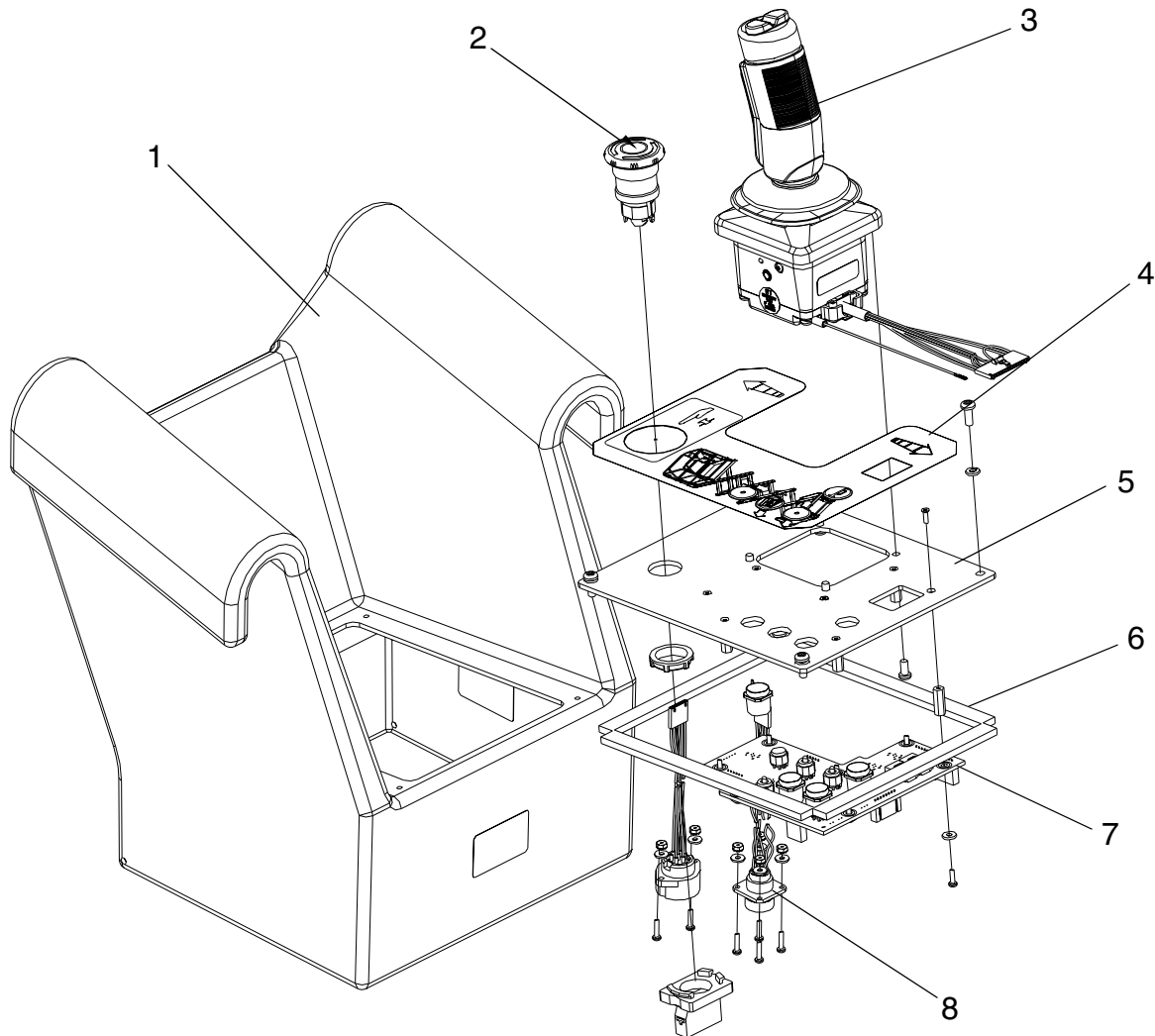

- 1. Control Box
- 2. Emergency Stop
- 3. Joystick
- 4. Decal

- 5. Mounting Plate
- 6. Box Seal
- 7. Circuit Board
- 8. Socket, Main Harness

CHASSIS CONTROLS

The chassis control assembly is mounted on the inside of the chassis door, to the left of the Hydraulic tank.

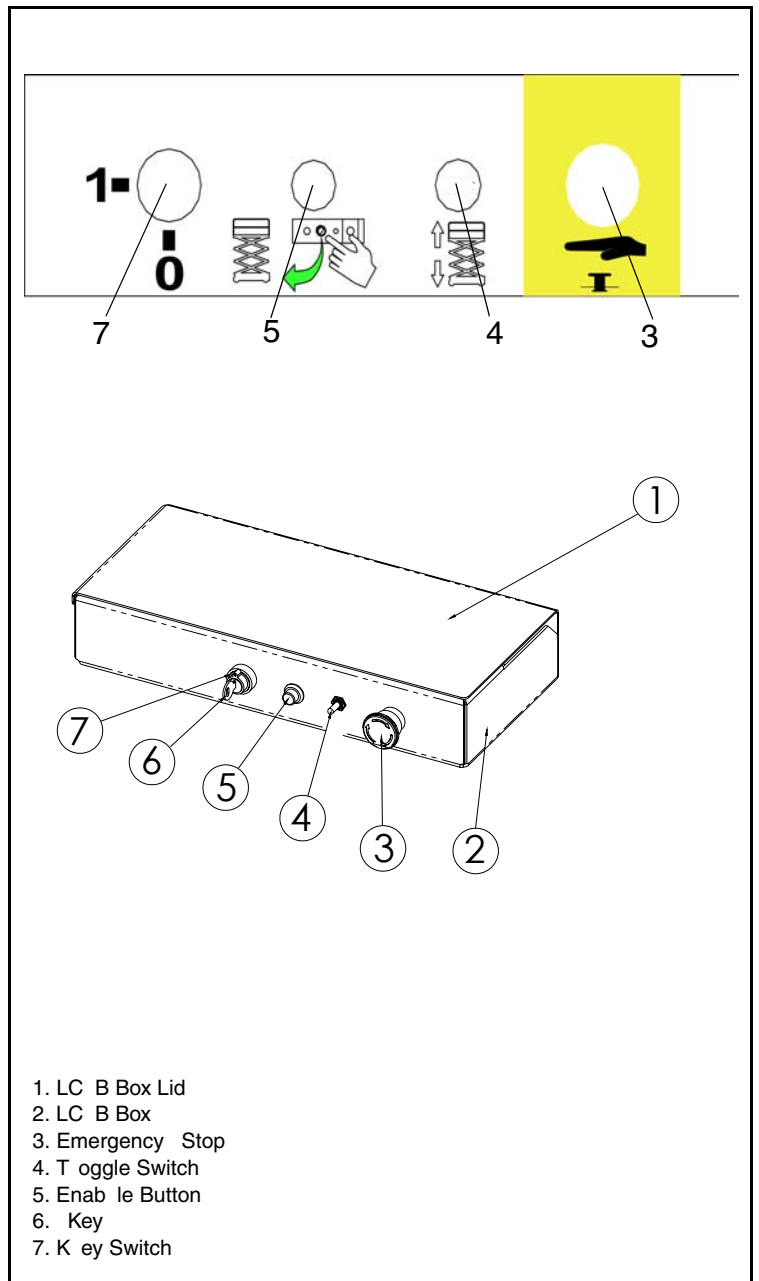

TROUBLESHOOTING

4.1 INTRODUCTION

The following section on troubleshooting provides guidelines on the types of problems users may encounter in the field, helps determine the cause of problems, and suggests proper corrective action.

Careful inspection and accurate analysis of the symptoms listed in the Troubleshooting Guide will localize the trouble more quickly than any other method. This manual cannot cover all possible problems that may occur. If a specific problem is not covered in this manual, call our number for service assistance.

Referring to Section 2.0 and 5.0 will aid in understanding the operation and function of the various components and systems and help in diagnosing and repair of the machine.

GENERAL PROCEDURE

Thoroughly study hydraulic and electronic schematics in **Section 5**. Check for loose connections and short circuits. Check/repair/replace each component in the Truth Table that is listed under each machine function that does not operate properly.

Use the charts on the following pages to help determine the cause of a fault.

NOTE: Spike protection diodes at components have been left out of the charts to eliminate confusion.

W A R N I N G

When troubleshooting, ensure that the work platform is resting on a firm, level surface.

When performing any service that requires the platform to be raised, ensure that the platform and booms are supported by a crane capable of supporting the load.

Unplug the machine or disconnect the battery when replacing or testing the continuity of any electrical component.

4.2 TROUBLESHOOTING

1. Verify your problem.
 - Do a full function test from both the platform and chassis controls, and note all functions that are not operating correctly.
2. Narrow the possible causes of the malfunction.
 - Use the troubleshooting guide to determine which components are common to all circuits that are not functioning correctly.
3. Identify the problem component.
 - Test components that are common to all circuits that are not functioning correctly. Remember to check wires and terminals between suspect components. Be sure to check connections to battery negative.
4. Repair or replace any component found to be faulty.
5. Verify that repair is complete.
 - Do a full function test from both the platform and chassis controls to verify that all functions are operating correctly and that the machine is performing to specified values.

SPECIAL TOOLS

Following is a list of tools which may be required to perform certain maintenance procedures on the X-Series work platforms.

- Flow Meter with Pressure Gauge (P/N 067040-000)
- 0-69 bar (0-1000 psi) Hydraulic Pressure Gauge with Adapter Fittings (P/N 014124-010)
- 0-207 bar (0-3000 psi) Hydraulic Pressure Gauge with Adapter Fittings (P/N 014124-030)
- Adapter Fitting (P/N 063965-002)
- Inclinator (P/N 010119-000)
- Crimping Tool (P/N 028800-009)
- Terminal Removal Tool (P/N 028800-006)

ADJUSTMENT PROCEDURES

Hydraulic settings must be checked whenever a component is repaired or replaced.

Remove counterbalance valves and "bench test" them if they are suspect.

Connect a pressure gauge of appropriate range to the test port located on the hydraulic manifold.

Correct pressure settings are listed in the hydraulic schematic.

CHECKING PUMP PRESSURES

Remove hose from pump port and connect pressure gauge.

4.3 TROUBLESHOOTING GUIDE

TROUBLE	PROBABLE CAUSE	REMEDY
All functions inoperable, electric motor does not start.	<ol style="list-style-type: none"> 1. Blown electric motor fuse 2. Faulty battery charger. 3. Faulty battery(ies). 4. Loose or broken battery lead. 5. Emergency Stop switch(es) failed open. 6. Blown control fuse 	<p>Check 160 amp electric motor fuse. Replace if blown.</p> <p>Check the voltage output of the battery charger. If less than 24 VDC,</p> <p>After completely charging batteries, test each battery. Replace as</p> <p>Check continuity of all battery and motor leads. Replace if necessary.</p> <p>With emergency stop switch in the ON position, check continuity</p> <p>Check 7A circuit control fuse. Replace if blown.</p>
All functions inoperable. Electric motor starts when control is actuated.	<ol style="list-style-type: none"> 1. Oil level in hydraulic reservoir is low. 2. Faulty hydraulic pump. 	<p>Check hydraulic fluid level, top off as required.</p> <p>Check pressure and delivery of the hydraulic pump. Replace if</p>
Platform will not elevate or elevates slowly.	<ol style="list-style-type: none"> 1. Emergency Lowering valve open. 2. Platform overloaded. 3. Faulty controller at upper controls. 4. Blown control fuse 5. Battery level low. Check for fault code 68 	<p>Close emergency down valve.</p> <p>Observe maximum load rating. (see Operation section of this manual)</p> <p>Check functionality of controller. Replace if faulty.</p> <p>Check 7A circuit control fuse. Replace if blown.</p> <p>Check Battery Voltage. Charge if necessary.</p>
Platform drifts down after being elevated	<ol style="list-style-type: none"> 1. Emergency lowering valve open. 2. Leaking piston seals in lift cylinders 	<p>Ensure that emergency lowering valve is completely closed. Replace</p> <p>Check for leakage at cylinder return line, replace seals if necessary.</p>

4.4 FAULT CODES INTRODUCTION

The X-Series is equipped with a fault detection system, if you have a faulty component, bad electrical connection or start up error a fault code will be displayed on the read out located on the upper control box.

For fault codes 01 - 39 the following procedure should be followed.

Ensure that no selector buttons are depressed.

Ensure that the deadman switch on the joystick is not held.

Ensure that the joystick is in neutral.

Ensure that the steer rocker is not activated.

Ensure that toggle switch is in neutral.

Then re-cycle power, do this by pushing and releasing the emergency stop button. If the fault code is still displayed you may have a faulty upper or lower control box, consult the error code list to identify the problem component and replace if necessary.

For fault codes 54 - 68 the following procedure should be followed.

1. Check the fault code list to identify the problem component.
2. Ensure that the wiring harness is connected, secure, in good condition and fully intact.
3. Ensure that the problem component is receiving electrical signal, consult the schematics in section 6 of this manual to identify the ECU output and harness test points.
4. If no ECU output is present replace the ECU.
5. If ECU output is present but no signal is reaching the component replace the wiring harness.
6. If signal is reaching the component but the component is not functioning replace the component (refer to section 7 of this manual for part number information).

4.5 FAULT CODES

- 01 – System initialization error
- 02 – System communication error
- 22 – Platform Left Turn Switch ON at power-up
- 23 – Platform Right Turn Switch ON at power-up
- 25 – Platform Hi-Drive Switch ON at power-up
- 27 – Platform Lo-Drive Switch ON at power-up
- 28 – Platform Lift Switch ON at power-up
- 29 – Platform Joystick Enable Switch ON at power-up
- 31 – Platform Joystick not in neutral at power-up
- 32 – Lower Control Up/DownToggle ON at power-up
- 39 – Lower Control Enable Switch ON at power-up

- 51 – Hi Speed / Low Speed Coil fault
- 54 – Pothole Retract Coil fault
- 55 – Lift Up Coil fault
- 56 – Lift Down Coil fault
- 59 – Steer Right Coil fault
- 61 – Steer Left Coil fault
- 66 – Forward Coil fault
- 67 – Reverse Coil fault

- 68 – Low Battery fault

4-6 ELECTRIC

Table 4-1: Electrical Troubleshooting Table

Component	Function	Lower Controls	Upper Controls	Drive Forward	Drive Reverse	High Speed/Creep	Raise Platform	Lower Platform	Steer Left	Steer Right	Depression Mechanism Extend	Depression Mechanism Retract	Brakes	Tilt Alarm	Down Alarm	Battery Charge
Alarm																
Batteries		X	X	X	X	X	X	X	X	X	X	X	X	X	X	
Battery Charger																X
5 AMP Circuit Breaker		X	X	X	X	X	X	X	X	X	X	X	X	X	X	
175 AMP Fuse		X	X	X	X	X	X	X	X	X	X	X	X			
ECU		X	X	X	X	X	X	X	X	X	X	X	X	X	X	
Motor Control		X	X	X	X	X	X	X	X	X	X	X	X			
Motor				X	X	X	X	X	X	X	X	X	X			
Chassis Emergency Stop Switch		X	X	X	X	X	X	X	X	X	X	X	X	X	X	
Chassis Key Switch		X	X	X	X	X	X	X	X	X	X	X	X	X	X	
Platform Emergency Stop Switch		X	X	X	X	X	X	X	X	X	X	X	X	X	X	
Interlock Switch			X	X	X	X	X	X	X							
PQ Control Handle			X	X	X		X	X								
Height Limit Switch							X									
Platform Steering Switch									X	X						
Tilt Sensor		X	X	X	X	X	X	X	X	X	X	X	X	X	X	
Steering Solenoid (right)										X						
Steering Solenoid (left)									X							
Platform Lift Solenoid							X									
Down Solenoid								X								
Reverse Solenoid					X											
Forward Solenoid				X												

4-7 HYDRAULIC

Table 4-2: Hydraulic Troubleshooting Table

Component	Function	Lift Platform	Lower Platform	Steer Right	Steer Left	Drive Forward	Drive Reverse	Creep	Depression Mechanism Extend	Depression Mechanism Retract	Brakes
Check Valve									X	X	
Steering Cylinder				X	X						
Lift Cylinder		X									
Depression Mechanism Cylinder									X	X	
Brake Cylinder											X
Suction Strainer		X		X	X	X	X	X	X	X	
Return Filter		X		X	X	X	X	X	X	X	
Drive Motors (2)						X	X				
Pump		X		X	X	X	X	X	X	X	
Main Relief Valve		X				X	X	X	X	X	X
Steering Relief Valve				X	X						
Lift Relief Valve		X									
Tank											
Steering Right/Left Valve				X	X						
Lift Valve		X									
Down/Emergency Lowering Valve			X								
Forward/Reverse Valve						X	X				
Counterbalance Valve						X	X	X			X

Notes :

SCHEMATICS

5.1 INTRODUCTION

This section contains electrical and hydraulic power schematics and associated information for maintenance purposes. The diagrams are to be used in conjunction with the information in **Section 4**. They allow understanding of the makeup and functions of the systems for checking, tracing, and faultfinding during troubleshooting analysis.

CONTENTS

Electrical Schematic	5-2
Cable Assembly (J1 Harness)	5-3
Schematic (J1 Harness)	5-4
Overload Schematic	5-5
Hydraulic Schematic (X26)	5-6
Hydraulic Schematic (X32)	5-7

5.2 ELECTRIC

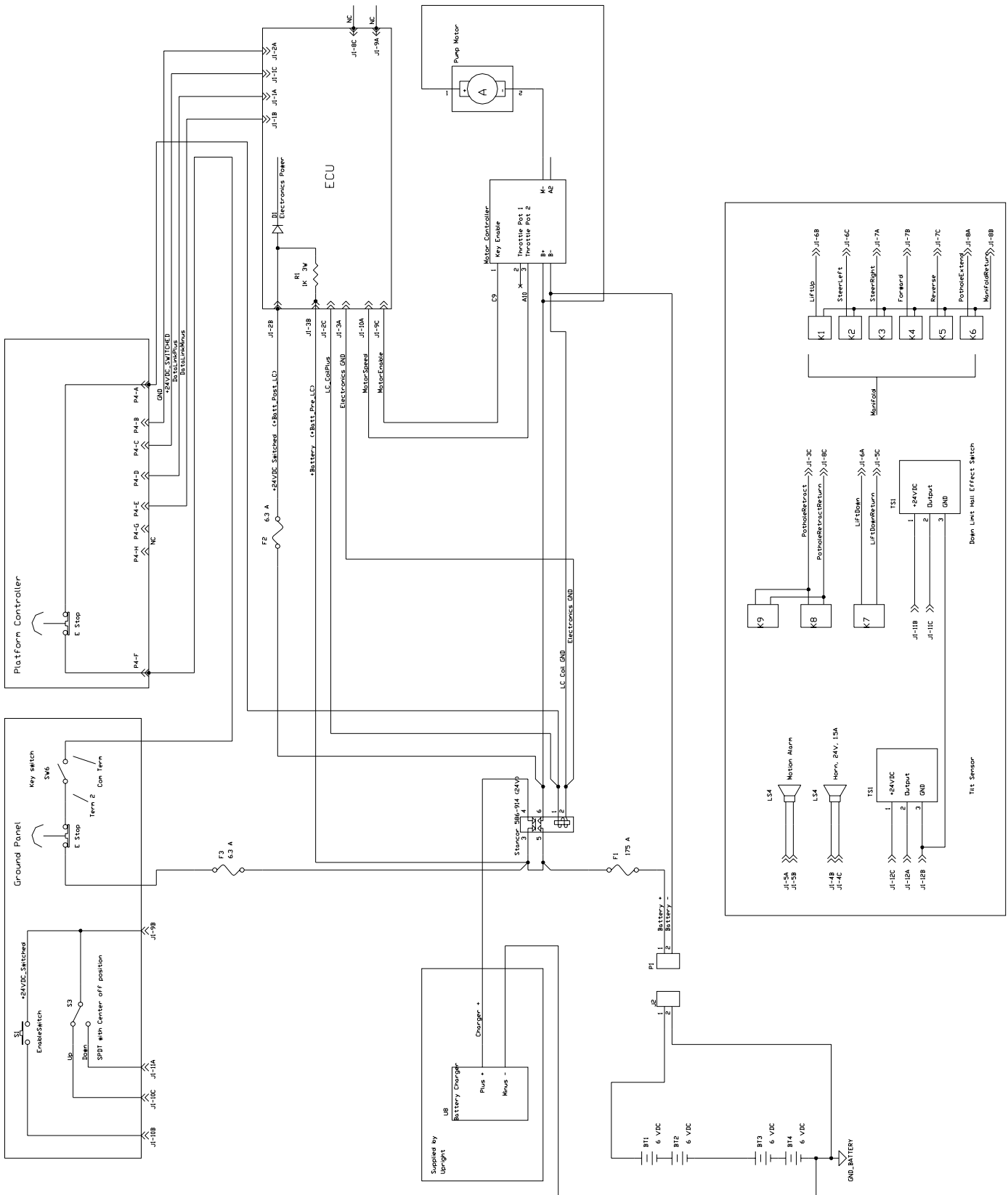

5.3 CABLE ASSEMBLY

WIRE INFORMATION

TABLE 1

ITEM NO.	POSITION	COLOR	LENGTH	ITEM NO.	POSITION	COLOR	LENGTH	ITEM NO.	POSITION	COLOR	LENGTH
1	A1	YELLOW, FROM ITEM 85	11176mm (4407)	13	B1	ORANGE, FROM ITEM 85	11176mm (4407)	25	C1	BROWN, FROM ITEM 85	11176mm (4407)
2	A2	BLACK, FROM ITEM 85	11176mm (4407)	14	B2	RED, SINGLE WIRE	2526mm (107)	26	C2	WHIT, SINGLE WIRE	5444mm (2147)
3	A3	BLACK, SINGLE WIRE	5444mm (2147)	15	B3	RED, SINGLE WIRE	5444mm (2147)	27	C3	PINK, FROM ITEM 88C	864mm (347)
4	A4	NOT USED	-----	16	B4	PINK, FROM ITEM 88B	508mm (207)	28	C4	GRAY, FROM ITEM 88A	508mm (207)
5	A5	ORANGE, SINGLE WIRE	9244mm (3647)	17	B5	BLACK, SINGLE WIRE	9244mm (3647)	29	C5	GRAY, FROM ITEM 88B	3810mm (1507)
6	A6	PINK, FROM ITEM 88A	3810mm (1507)	18	B6	LIGHT BLUE, SINGLE WIRE	750mm (2957)	30	C6	WHITE/BLUE, SINGLE WIRE	750mm (2957)
7	A7	WHITE/BLACK, SINGLE WIRE	750mm (2957)	19	B7	BLUE/BLACK, SINGLE WIRE	750mm (2957)	31	C7	ORANGE, SINGLE WIRE	750mm (2957)
8	A8	WHITE, SINGLE WIRE	750mm (2957)	20	B8	BLACK, SINGLE WIRE	750mm (2957)	32	C8	GRAY, FROM ITEM 88C	864mm (347)
9	A9	NOT USED	-----	21	B9	RED, SINGLE WIRE	1500mm (597)	33	C9	BLACK, SINGLE WIRE	696mm (2747)
10	A10	RED, SINGLE WIRE	696mm (2747)	22	B10	BLUE, SINGLE WIRE	1500mm (597)	34	C10	BLUE/PURPLE, SINGLE WIRE	1500mm (597)
11	A11	BLACK/ORANGE, SINGLE WIRE	1500mm (597)	23	B11	PINK #1, FROM ITEM 89A	696mm (2747)	35	C11	GRAY #2, FROM ITEM 89B	696mm (2737)
12	A12	GRAY #2, FROM ITEM 89B	4959mm (1957)	24	B12	BLUE #3, FROM ITEM 89B	4959mm (1957)	36	C12	PINK #1, FROM ITEM 89B	4959mm (1957)

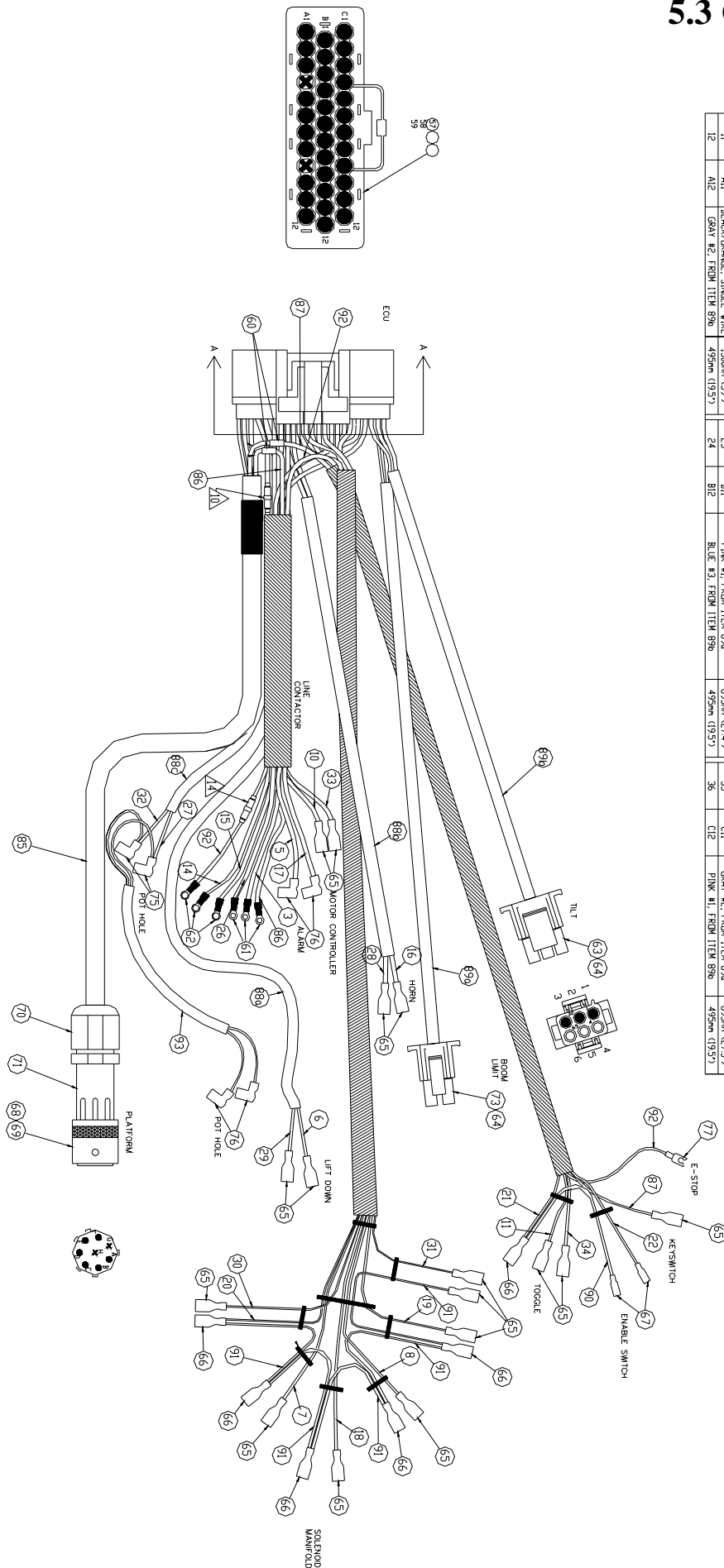

5.5 OVERLOAD SCHEMATIC

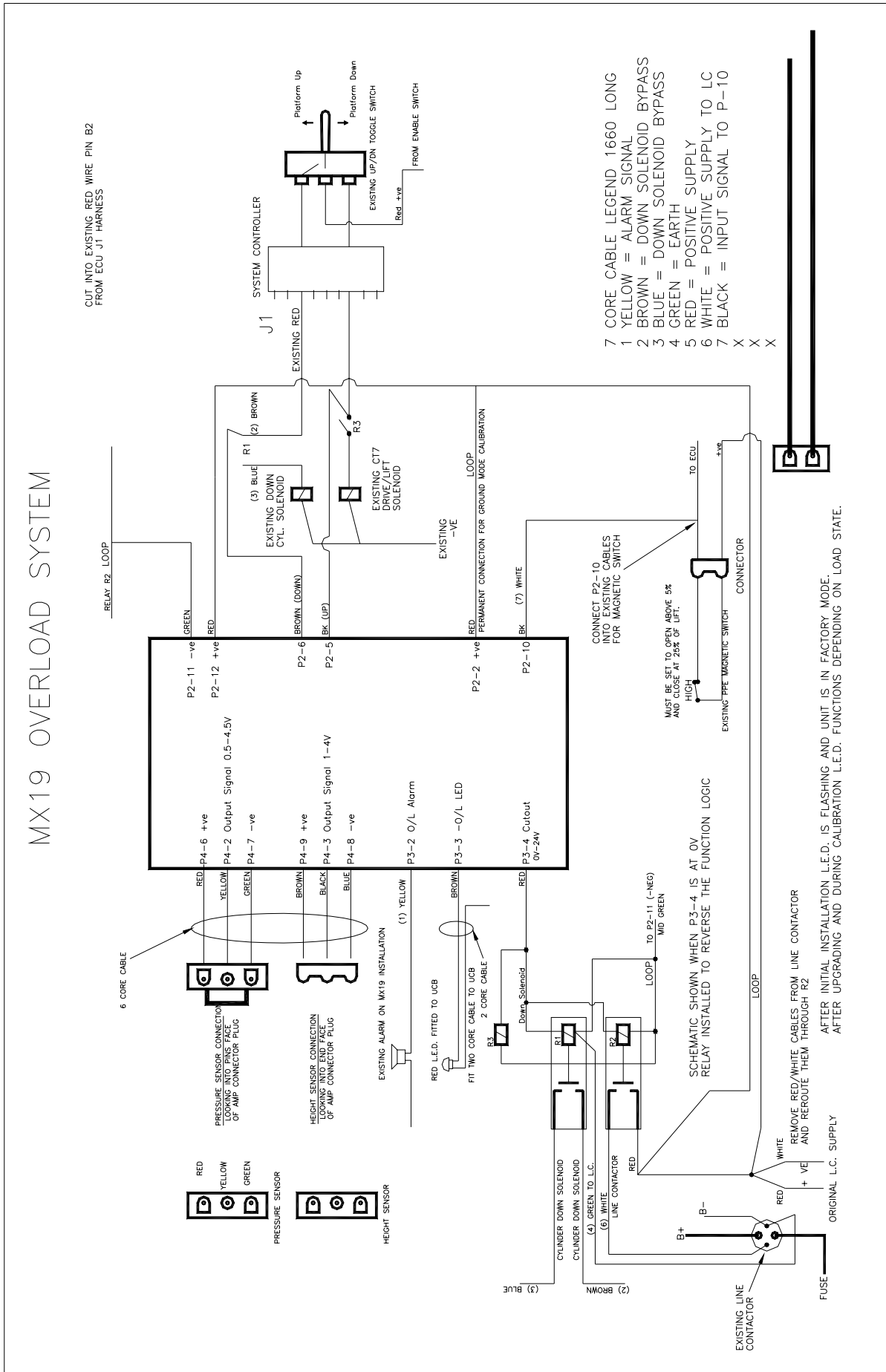

5.6 Hydraulic Schematic (X26)

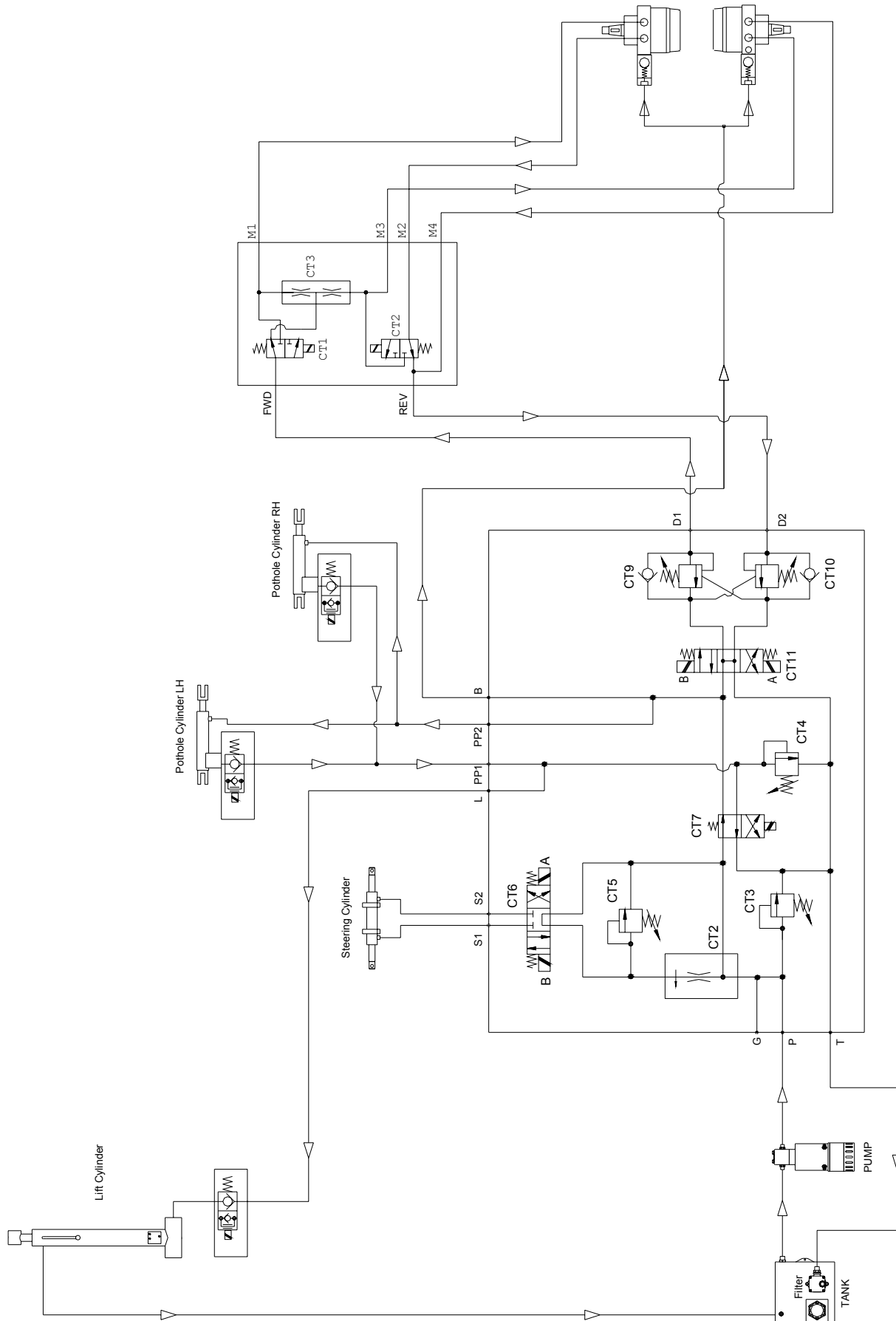

5.6 Hydraulic Schematic (X32)

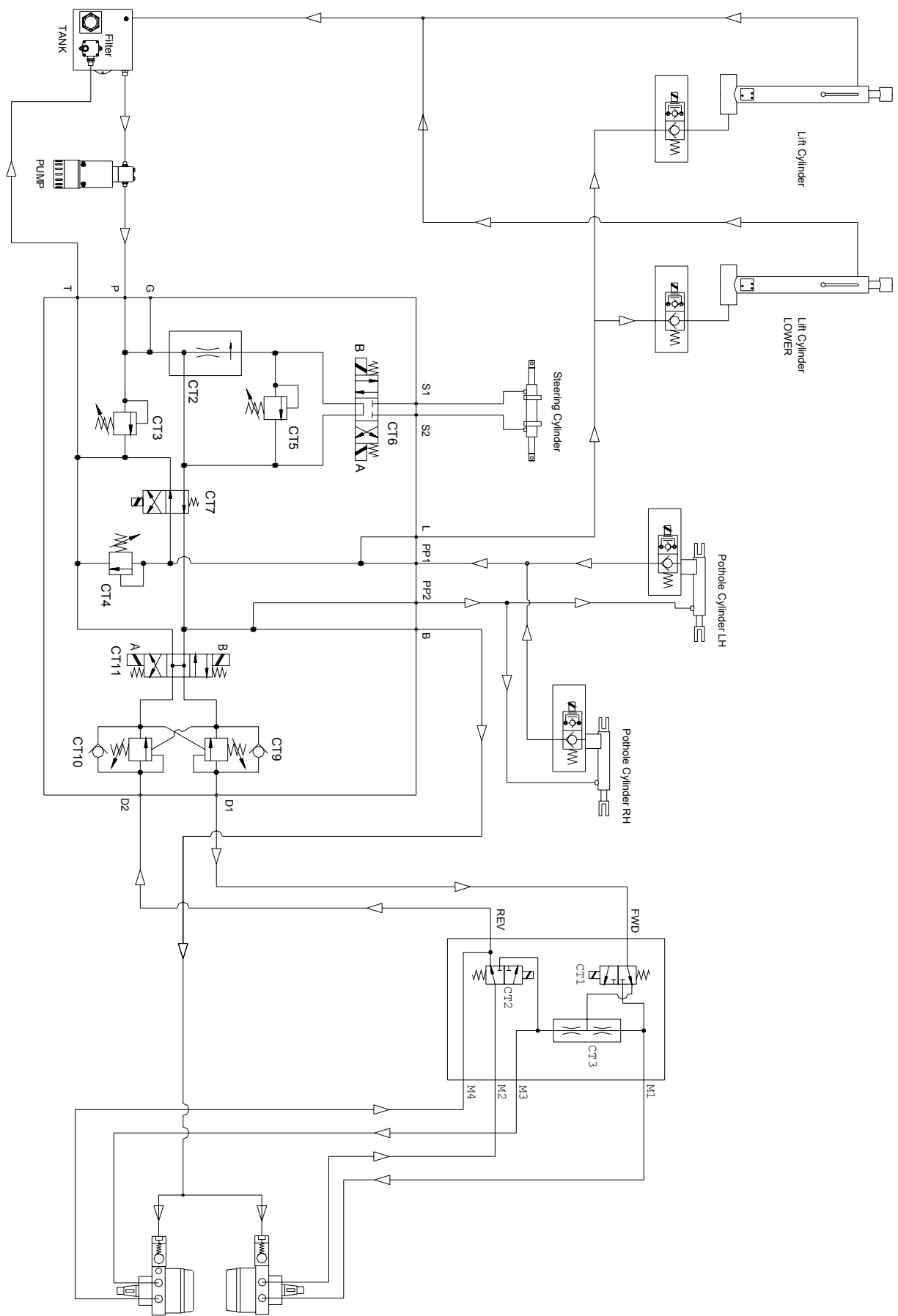

ILLUSTRATED PARTS BREAKDOWN

6.1 INTRODUCTION

This section lists and illustrates the replaceable assemblies and parts of this product, as manufactured by **UpRight**.

Each parts list contains the component parts for that assembly.

CONTENTS

General Assembly	6 - 2	Hydraulic Assembly (X26)	6 - 21
Chassis Assembly	6 - 3	Hydraulic Assembly (X32)	6 - 23
Scissor Assembly	6 - 6	Hydraulic Cylinder (Lift, Lower)	6 - 25
Platform Assembly (X26)	6 - 12	Hydraulic Cylinder (Lift, Upper)	6 - 26
		Hydraulic Cylinder (Steer)	6 - 27
Power Module Assembly (X26 & X32)	6 - 14	Hydraulic Cylinder (Pothole)	6 - 28
Control Module Assembly (X26 & X32)	6 - 15	Electrical Assembly (X26)	6 - 19
Control Valve Assembly	6 - 16	Electrical Assembly (X32)	6 - 30
Lower Control Box Assembly	6 - 17	Overload Assembly	6 - 31
Hydraulic Tank Assembly	6 - 18	Decal Assembly (X26)	6 - 33
Upper Control Box Assembly	6 - 19	Decal Assembly (X32)	6 - 34
Hydraulic Block Assembly (Series / Parallel)	6 - 20		

General Assembly

504000-000 (X26)

Item	Part	Description	QTY.
1	504001-000	CHASSIS ASSEMBLY	1
2	504002-000	SCISSOR ASSEMBLY	1
3	504003-000	PLATFORM ASSEMBLY	1
4	504007-000	HYDRAULIC ASSEMBLY	1
5	504008-000	ELECTRICAL ASSEMBLY	1

504200-000 (X32)

Item	Part	Description	QTY.
1	504201-000	CHASSIS ASSEMBLY	1
2	504202-000	SCISSOR ASSEMBLY	1
3	504203-000	PLATFORM ASSEMBLY	1
4	504207-000	HYDRAULIC ASSEMBLY	1
5	504208-000	ELECTRICAL ASSEMBLY	1

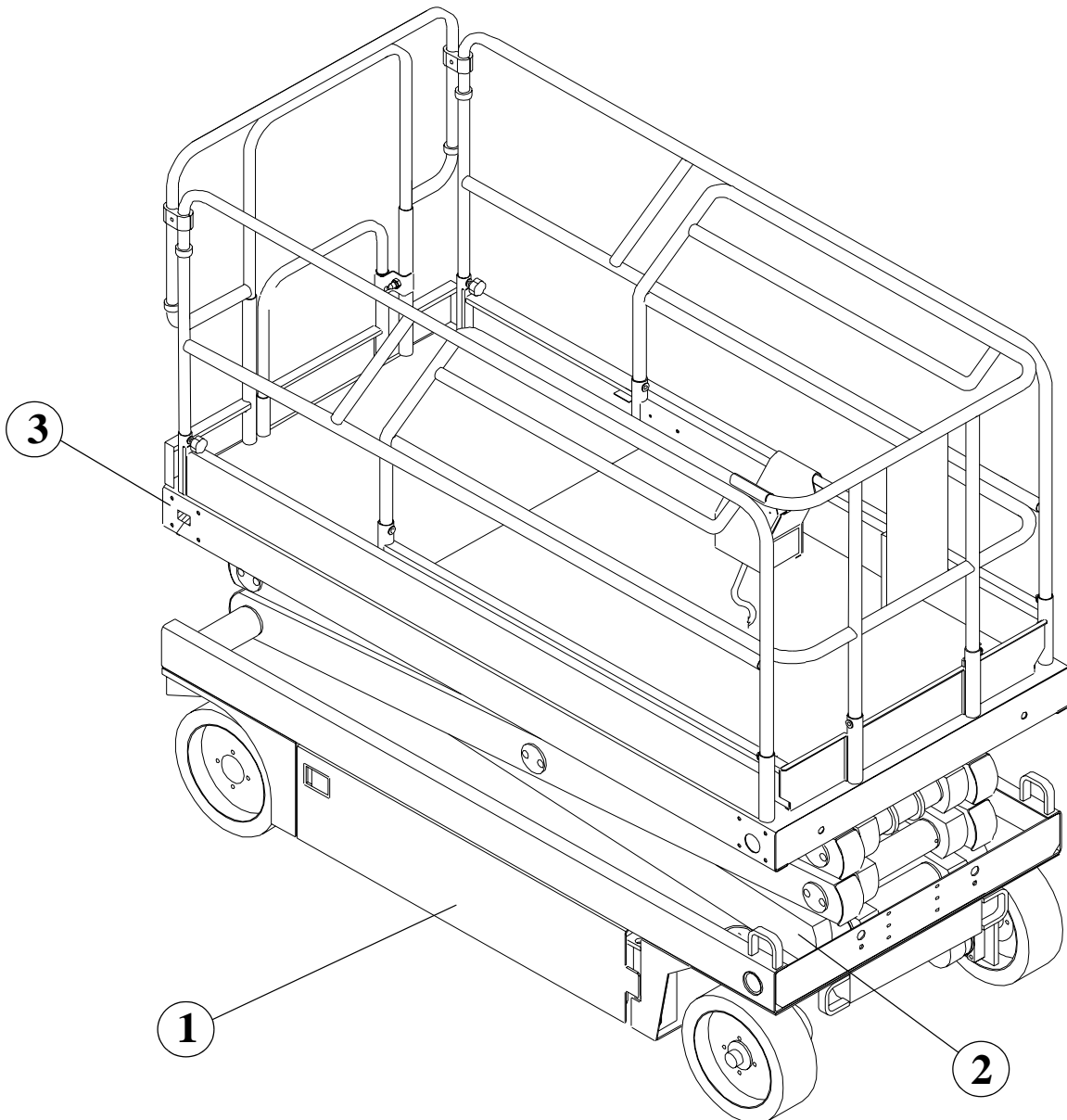

Chassis Assembly X26 & X32

504001-000 (X26) & 504201-000 (X32)

ITEM	PART NUMBER	DESCRIPTION	QTY
1	066750-000	CHASSIS WELDMENT	1
2	114058-000	WHEEL YOKE/MOTOR MOUNT (RHS)	1
3	114057-000	WHEEL YOKE/MOTOR MOUNT (LHS)	1
4	066151-001	STEERINGLINK (RHS)	1
5	066152-001	STEERINGLINK (LHS)	1
6	066069-002	BELL CRANK WELDMENT	1
7	502171-000	WHEEL HUB (FRONT)	2
8	502170-000	WHEEL	2
9	504150-000	WEAR PAD (BELL CRANK)	2
10	504154-000	PIVOT PIN (BELL CRANK)	1
11	504144-001	BUSHING	2
12	504153-000	PIVOT PIN, STEERING CYLINDER (ROD END)	1
13	114055-000	MOTOR, HYDRAULIC	2
14	504148-000	HYDRAULIC CYLINDER (STEERING)	1
15	504033-000	COVER, TILT SENSOR	1
16	503761-000	WASHER	2
17	503689-000	MOUNTING BRACKET, LIMIT SWITCH	1
18	503755-000	CASTLE NUT	4
19	504167-000	PIVOT PIN, STEERING CYLINDER (BODY END)	1

ITEM	PART NUMBER	DESCRIPTION	QTY
20	510668-000	SPACER, STEERING BOSS	2
21	505045-000	SPACER, BELL CRANK	2
22	503672-001	BUSHING, STEERING CYLINDER	1
23	503673-001	BUSHING, STEERING LINK	4
24	504155-001	WEAR PAD (STEERING LINK)	2
25	065733-000	WASHER (KING PIN)	2
26	503673-000	BUSHING, BELL CRANK PIVOT PIN	1
27	502152-000	SPLIT PIN	4
28	066307-001	LADDER	1
29	066731-025	LADDER BRACKET	2
30	066774-030	LADDER STAND (RHS)	1
31	066774-031	LADDER STAND (LHS)	1
32	502171-003	WHEEL HUB, REAR	2
33	504157-000	ROLLER BEARING	4
34	502097-000	SPACER, PAINTED	4
35	503755-000	CASTLE NUT	2
36	504158-000	DUST SEAL	2
37	502170-000	WHEEL	2
38	504159-000	GREASE SEAL	2
39	011254-010	Bolt 3/8" UNC X 1 1/4"	2
40	011250-006	NUT 3/8" UNC	2
41	510672-000	BUSHING small	2

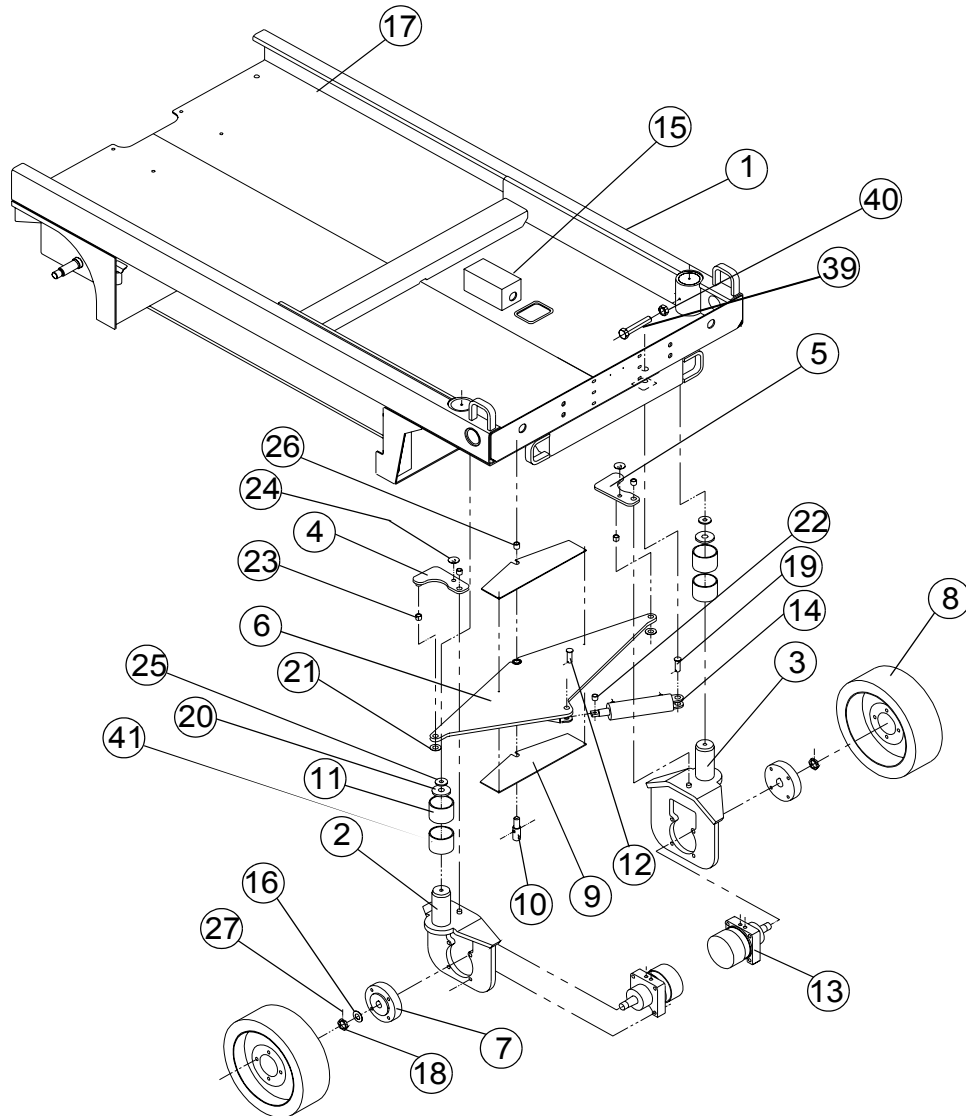

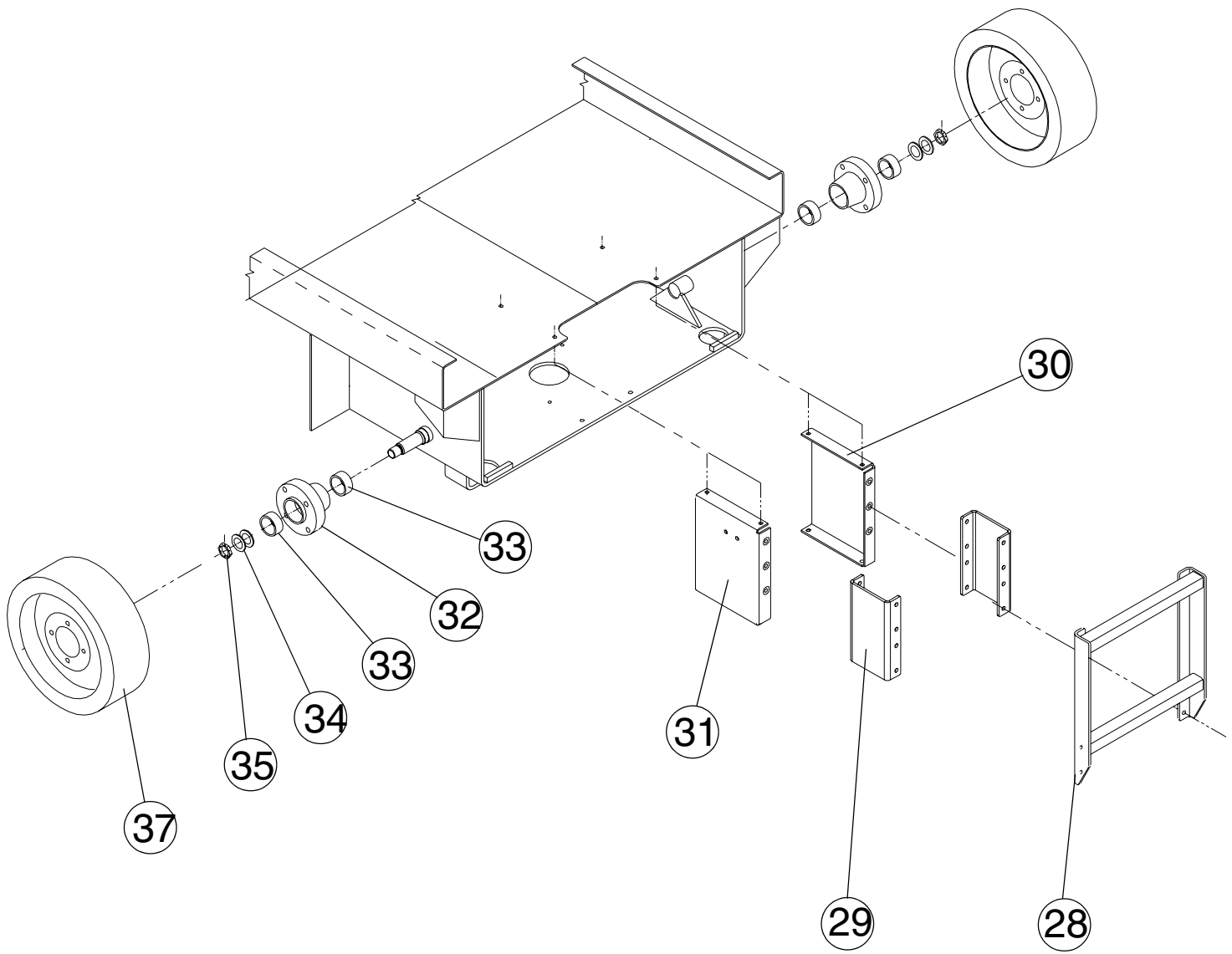

Notes

Scissor Assembly X26

500002-000

Item	Part	Description	QTY.
1	504101-000	SCISSOR WELDMENT - OUTER TOP & BOTTOM	2
2	504103-000	SCISSOR WELDMENT - OUTER STANDARD	1
3	504103-001	SCISSOR WELDMENT - OUTER STANDARD 3rd	2
4	504103-002	SCISSOR WELDMENT - OUTER STD(C/W BRACKET)	1
5	504104-001	SCISSOR WELDMENT - INNER STANDARD	1
6	504106-002	SCISSOR WELDMENT - INNER CYLINDER	1
7	504106-003	SCISSOR WELDMENT - INNER TOP	1
8	504106-004	SCISSOR WELDMENT - INNER BOTTOM	1
9	504186-000	PIVOT PIN - CHASSIS / PLATFORM	6
10	504122-004	PIVOT PIN - CYLINDER BODY & ROD	1
11	504122-003	PIVOT PIN - STANDARD (LONG)	2
12	504122-002	PIVOT PIN - SCISSOR STANDARD	11
13	504122-005	PIVOT PIN - SCISSOR STANDARD (TAPPED)	2
14	504186-001	PIVOT PIN - CHASSIS (FIXED)	2
15	504122-001	PIVOT PIN - STANDARD, MEDIUM	3
16	504123-000	PIVOT PIN - CYLINDER ROD	1
17	504038-000	PIVOT PIN - SCISSOR BRACE	3
18	504129-000	MAIN LIFT CYLINDER	1
19	504029-000	CABLE GUIDE CHANNEL	1
20	503790-001	SHORT CABLE GUIDE	1
21	504046-000	PIVOT BRACKET	2
22	504120-000	FLANGED BUSHING, 50mm	46
23	058819-000	GREASE NIPPLE, M6	14
24	504120-001	PLAIN BUSH, 50mm	2
25	504189-001	WASHER, M48 X 4mm THICK	2
26	056687-100	HEX HEAD BOLT, M16 X 100mm	1
27	056069-016	WASHER, M16	2
28	501449-000	FLANGED BUSHING, 16mm	2
29	504177-000	ROLLER, TORSION ARM	1
30	056066-016	NYLOCK NUT, M16	1
31	504176-000	WELDMENT, TORSION ARM (LHS)	1
32	504176-001	WELDMENT, TORSION ARM (RHS)	1

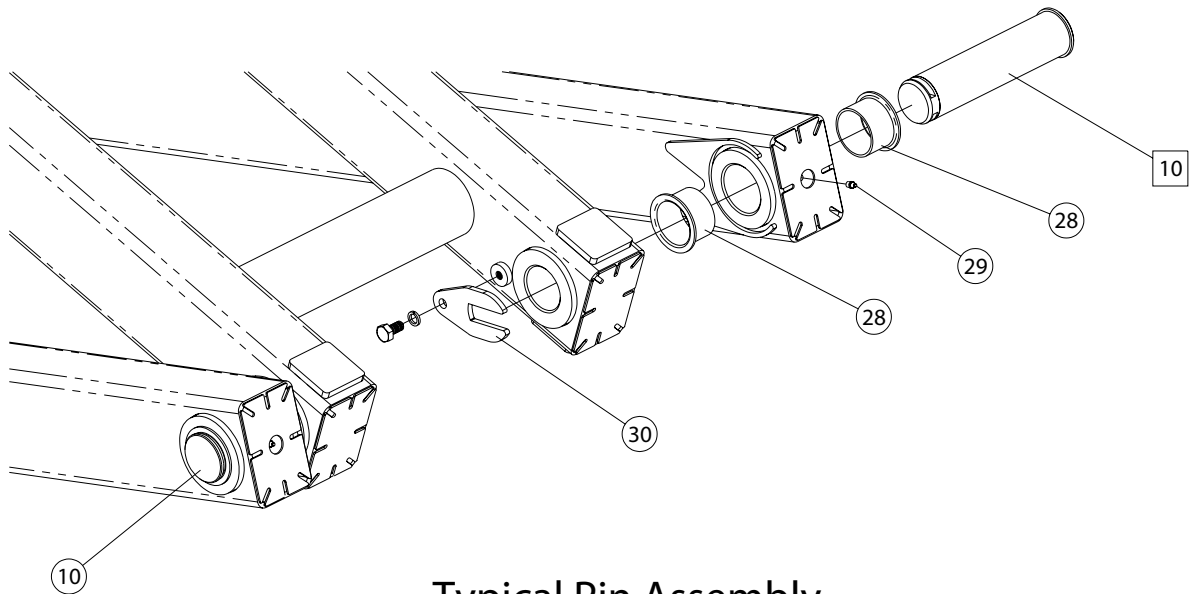

Typical Pin Assembly

Inside Scissor Members & Trunking

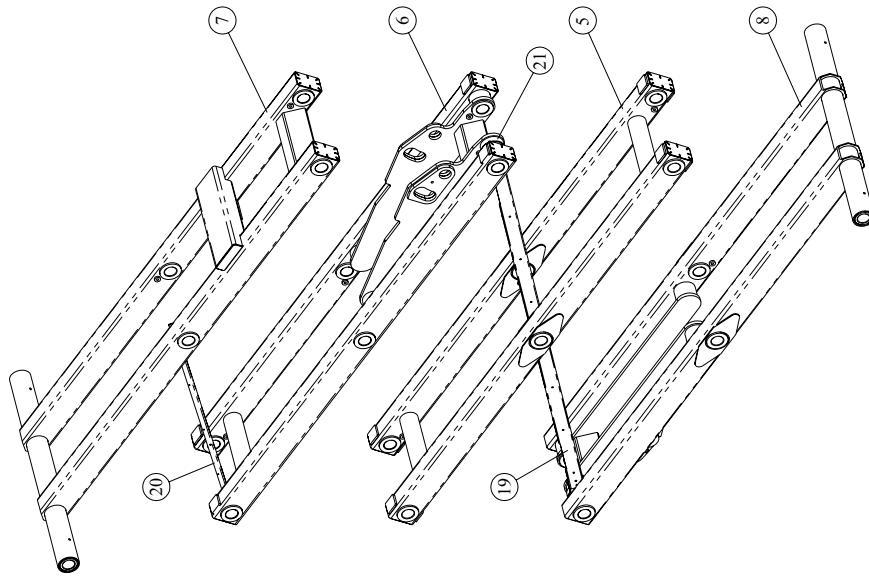

Pivot Pins & Cylinder

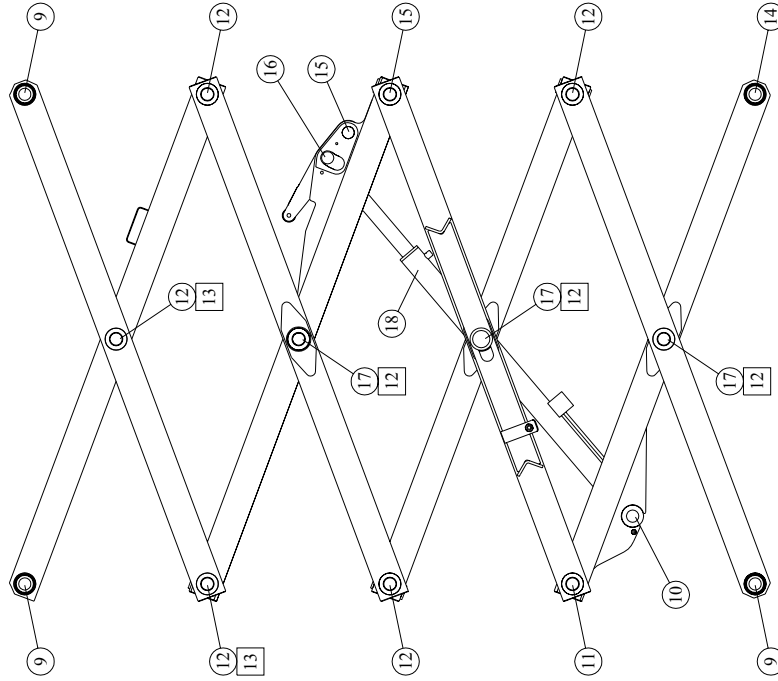

DENOTES PINS THAT ARE IN THE FOREGROUND

Outside Scissor Members

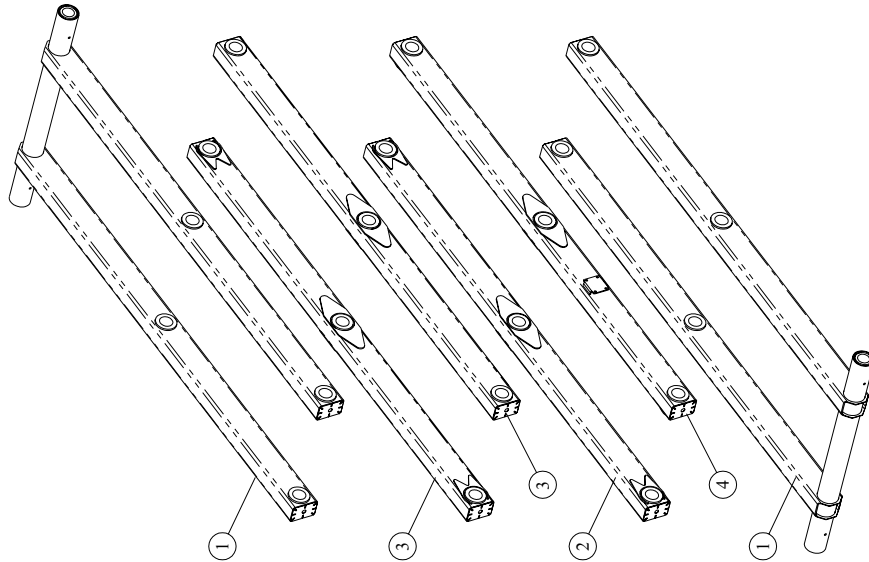

Scissor Assembly X32

504202-000

Item	Part	Description	QTY.
1	504101-000	SCISSOR WELDMENT - OUTER TOP & BOTTOM	2
2	504103-000	SCISSOR WELDMENT - OUTER STANDARD	5
3	504103-002	SCISSOR WELDMENT - OUTER STD(C/W BRACKET)	1
4	504104-001	SCISSOR WELDMENT - INNER STANDARD	2
5	504106-000	SCISSOR WELDMENT - INNER TOP	1
6	504106-001	SCISSOR WELDMENT - INNER, CYLINER	1
7	504106-004	SCISSOR WELDMENT - INNER BOTTOM	1
8	504186-000	PIVOT PIN - CHASSIS / PLATFORM	6
9	504122-004	PIVOT PIN - CYLINDER BODY / ROD	2
10	504122-003	PIVOT PIN - STANDARD LONG	4
11	504122-002	PIVOT PIN - SCISSOR STANDARD	14
12	504122-000	PIVOT PIN - MID-CYLINDER MEMBER	2
13	504122-001	PIVOT PIN - STANDARD - MEDIUM	5
14	504186-001	PIVOT PIN - CHASSIS, FIXED	2
15	504038-000	PIVOT PIN - SCISSOR BRACE	2
16	504039-000	PIVOT PIN - SCISSOR BRACE (TOP)	1
17	504129-000	MAIN LIFT CYLINDER	1
18	504124-000	LIFT CYLINDER	1
19	504046-000	PIVOT BRACKET	4
20	504029-000	CABLE GUIDE CHANNEL	2
21	504043-000	WELDMENT, SCISSOR BRACE	1
22	009442-003	SPRING PLUNGER ASSEMBLY	1
23	504036-000	SCISSOR BRACE WELDMENT	1
24	504040-000	CLAMP WASHER	1
25	066189-004	SPACER PAD - 6mm	1
26	066189-001	SPACER PAD - 10mm	1
27	504189-000	M48 WASHER (8mm THICK)	2
28	504120-000	FLANGED BUSHING, 50mm	60
29	056819-000	GREASE NIPPLE, M6	20
30	504187-000	PIN LOCK PLATE	30

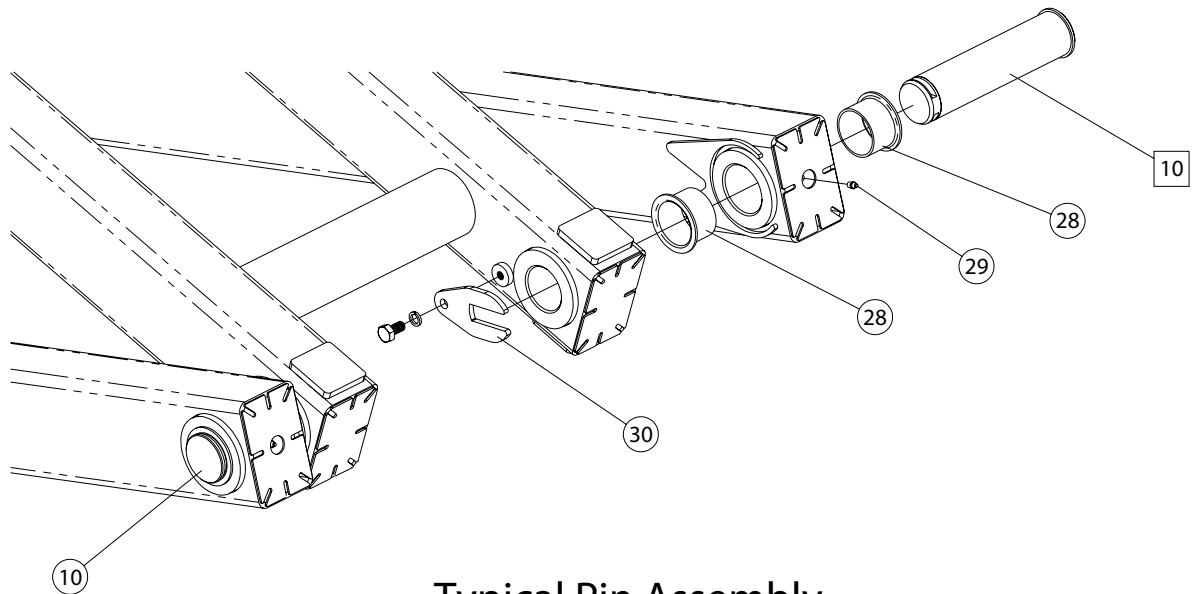

Typical Pin Assembly

Inside Scissor Members & Trunking

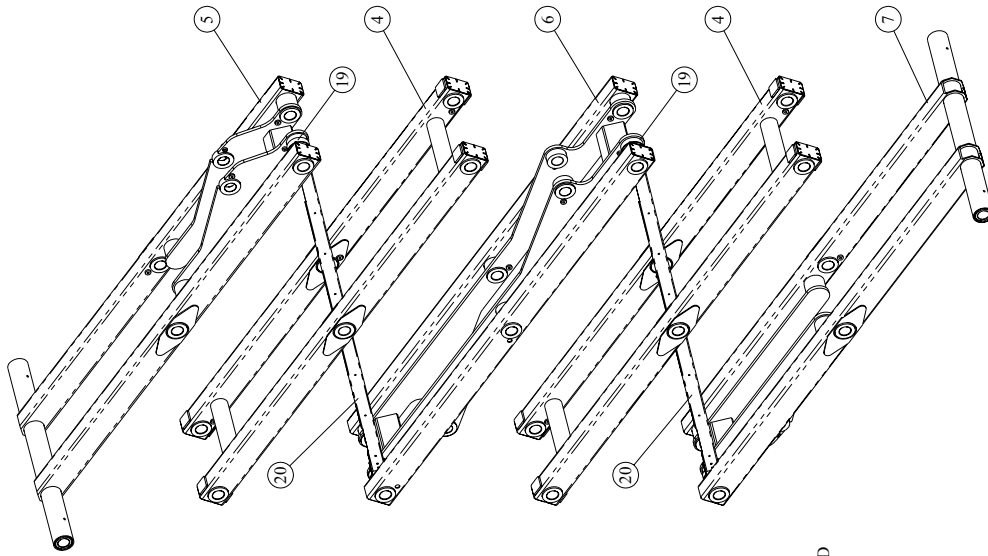

Pivot Pins & Cylinders

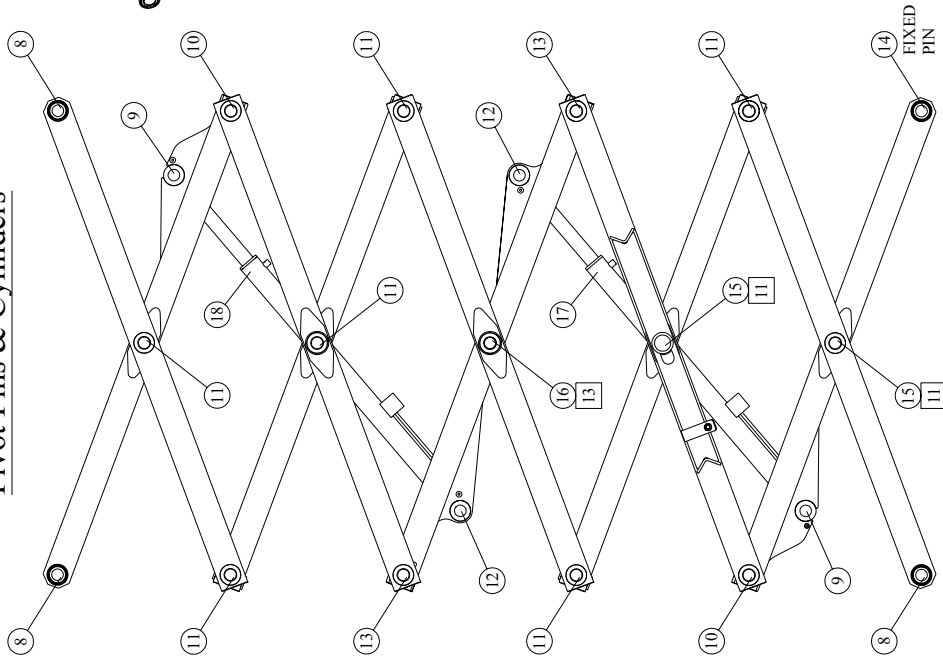

Outside Scissor Members

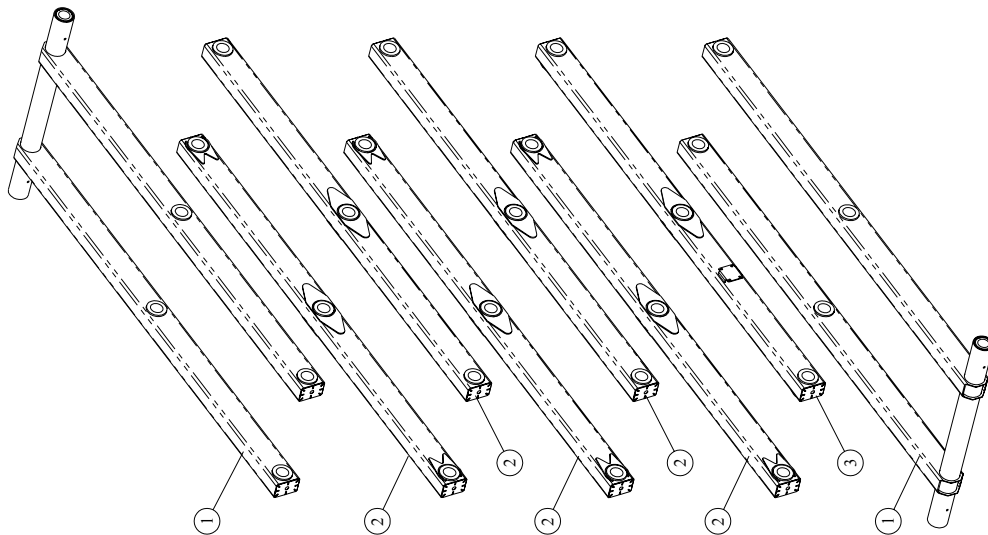

DENOTES PINS THAT ARE IN THE FOREGROUND

Scissor Assembly X26 (Lift Assist Assembly)

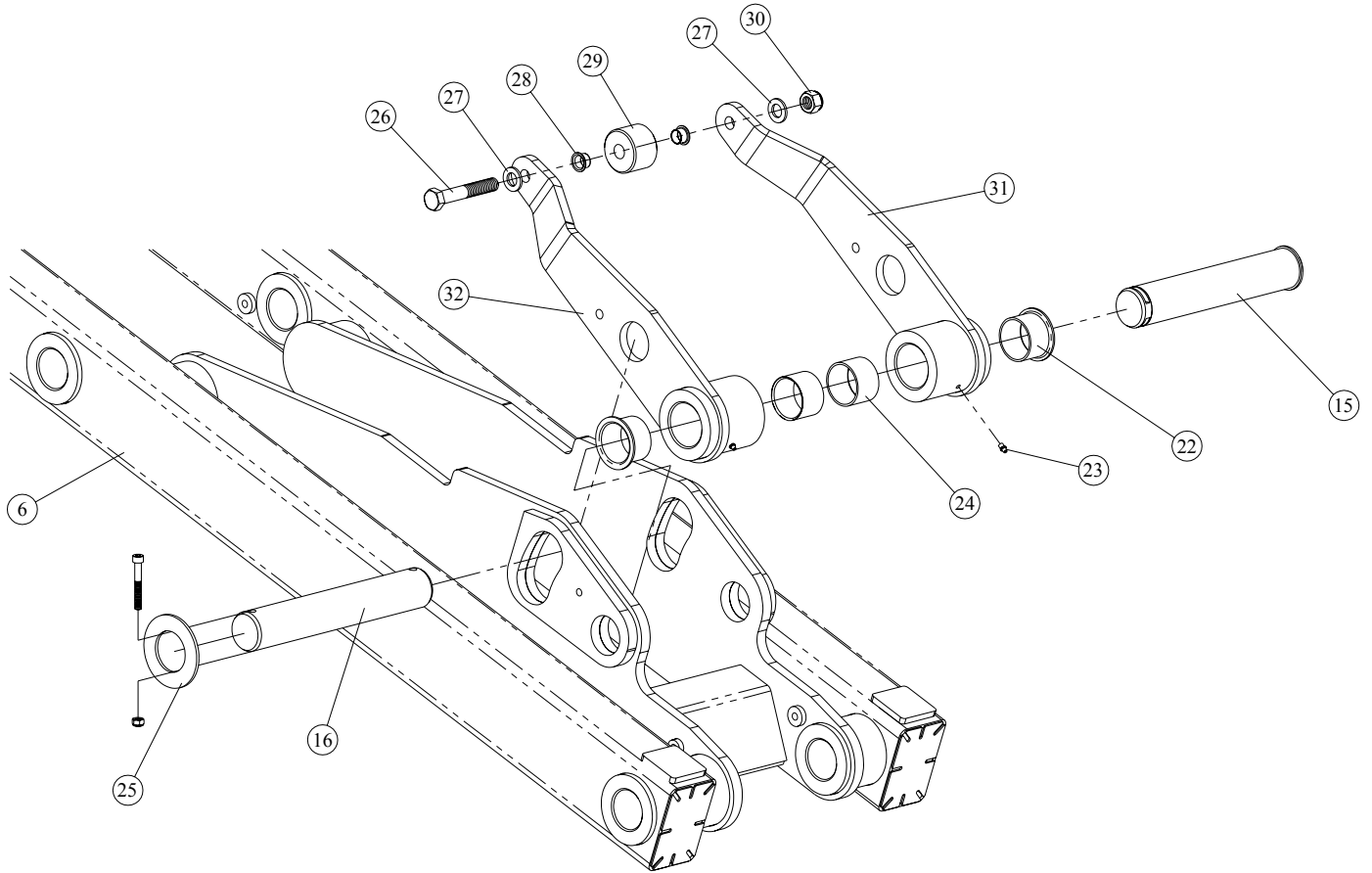

Lift Assist Assembly

Scissor Brace Assembly X26 & X32

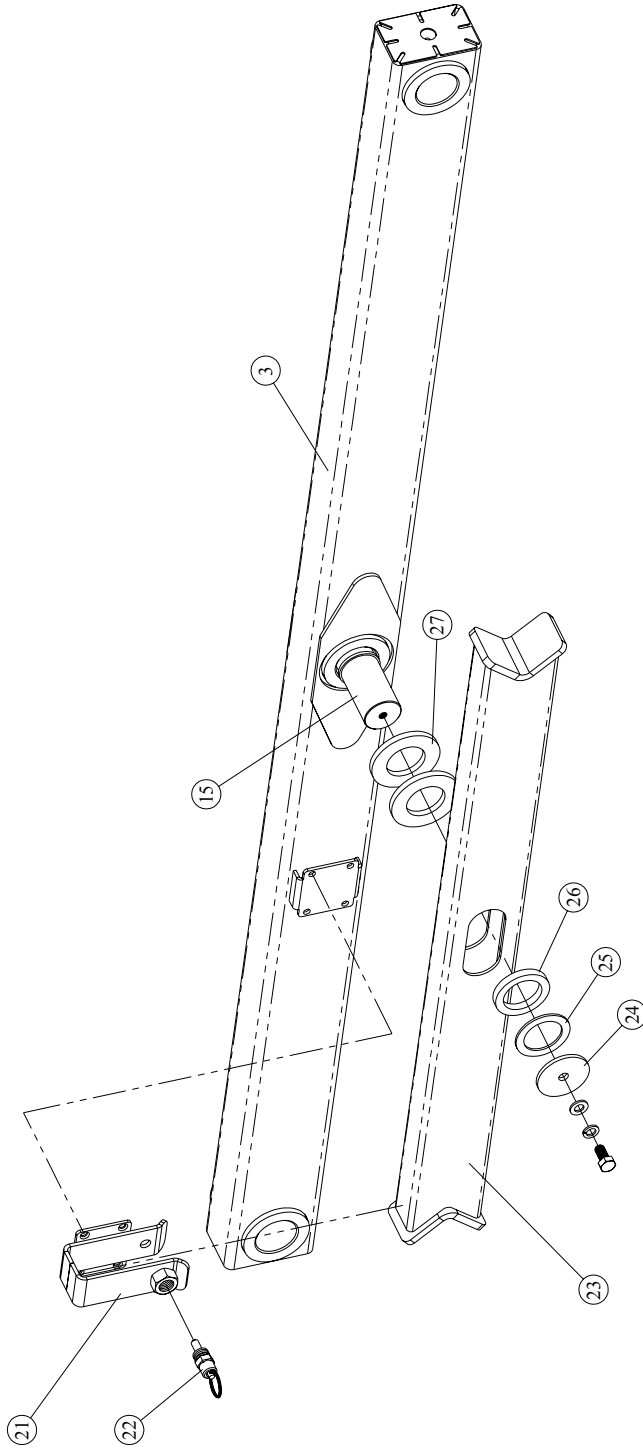

Scissor Brace Assembly

Platform Assembly X32

504203-001

Item	Part	Description	QTY.
1	066262-001	WELDMENT, X32 PLATFORM	1
2	504138-000	LIFT STOP BRACKET	2
3	502148-001	WEAR PAD	2
4	504310-001	RAIL WELDMENT, PLATFORM RHS	1
5	504311-001	WELDMENT, DROP RAIL RHS	1
6	504311-000	WELDMENT, DROP RAIL LHS	1
7	504310-000	RAIL WELDMENT, PLATFORM LHS	1
8	502131-000	GUIDE WEAR PAD	2
9	502132-001	ROLLER, EXTENSION DECK	2
10	502129-000	ROLLER STOP	4
11	BELOW	LOCK PIN ASSEMBLY	1
A	502322-000	LOCK PIN	1
B	502323-000	R-CLIP	1
C	058296-000	KEY RING	1
D	53192	CABLE	2
E	53195-02	CABLE CRIMP	4
12	504314-000	WELDMENT, SWING BAR	1
13	058557-000	PLASTIC CAP	3
14	057094-001	HARNESS HARDPOINT BRACKET	1
15	504026-000	BRACKET, GATE STOP	2
16	504315-000	WELDMENT, GATE	1
17	501352-001	LATCH	1
18	502204-001	GATE SPRING	1
19	502206-001	INSERT, GATE PIVOT	1
20	502231-000	PIPE CLAMP	1

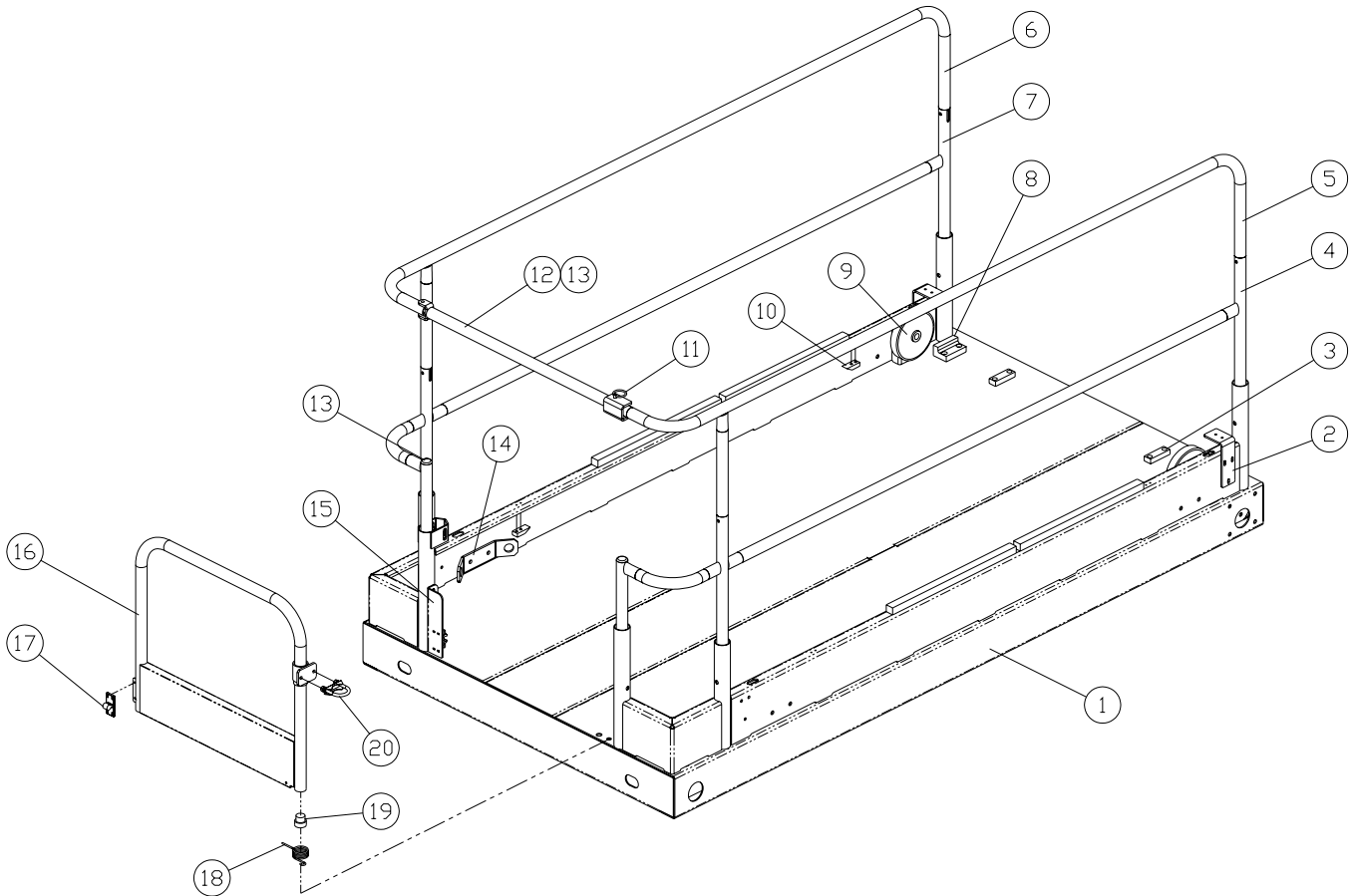

Extension Deck Assembly X32

504203-002

Item	Part	Description	QTY.
1	066294-002	WELDMENT, EXTENSION DECK	1
2	-	GUIDE STRIP	2
3	502168-001	DECAL PANEL	1
4	504312-000	WELDMENT, EXTENSION DECK RAIL	1
5	504313-001	WELDMENT, SIDE DROP RAIL (RHS)	1
6	010076-000	MANUAL HOLDER	1
7	504314-000	WELDMENT, SWING BAR	1
8	058557-000	PLASTIC CAP	1
9	BELOW	LOCK PIN ASSEMBLY	1
A	502322-000	LOCK PIN	1
B	502323-000	R-CLIP	1
C	058296-000	KEY RING	1
D	53192	CABLE	2
E	53195-02	CABLE CRIMP	4
10	504313-000	WELDMENT, SIDE DROP RAIL (LHS)	1
11	502141-000	LEVER BRACKET	1
12	009442-003	PLUNGER PIN ASSEMBLY	1
13	057094-001	HARNESS HARDPOINT BRACKET	1
14	502148-001	WEAR PAD	2
15	502145-000	WELDMENT, LEVER PIVOT BRACKET	1
16	504021-000	WELDMENT, ROLLER MOUNT	2
17	502097-000	ROLLER SHIM	2
18	502132-001	EXTENSION DECK ROLLER	2

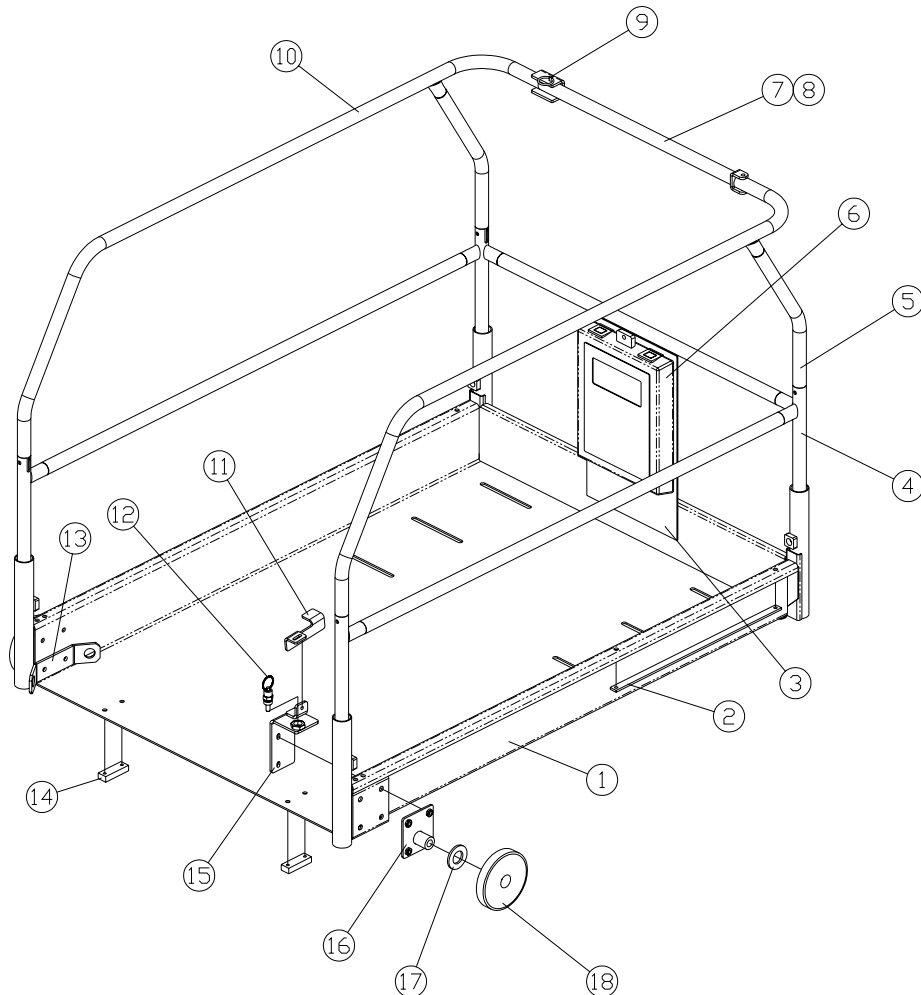

Power Module Assembly

X26 & X32

Item	Part	Description	QTY.
1	501074-000	BATTERY	4
2	066309-011	WELDMENT, DOOR MODULE	1
3	062791-002	LATCH	1
4	066735-001	WELDMENT, POTHOLE	1
5	504133-000	BRACKET, GUIDE PAD ANGLE	1
6	066713-002	HINGE	1
7	-	-	-
8	504132-000	HYDRAULIC CYLINDER, POTHOLE	1
9	504153-001	PIVOT PIN, POTHOLE	2
10	504135-000	BUSHING, POTHOLE PIVOT	2
11	504126-000	BUSHING, MODULE PIVOT	2
12	500858-001	SPLIT PIN	1
13	-	-	-
14	504134-000	GUIDE PAD	2
15	-	-	-

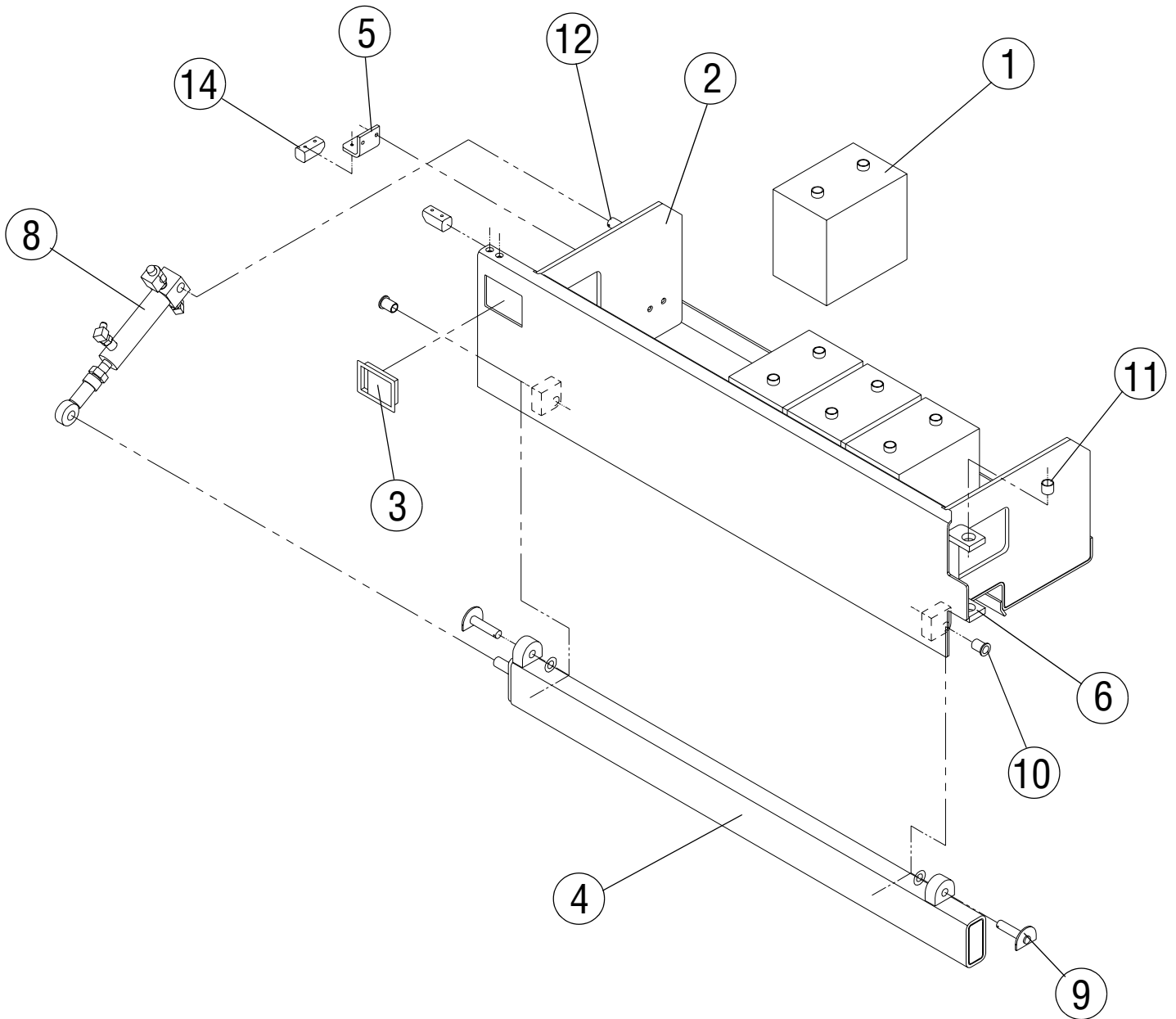

Control Module Assembly

X26 & X32

Item	Part	Description	QTY.
1	504128-001	HYDRAULIC TANK	1
2	062791-002	LATCH	1
3	502588-000	ALARM	1
4	502489-000	LINE CONTACTOR	1
5	502494-000	MAIN FUSE	1
6	503758-000	MOUNTING PLATE, FUSE	1
7	066310-010	WELDMENT, CONTROL MODULE	1
8	504126-000	BUSHING, MODULE HINGE	2
9	504135-000	BUSHING, POTHOLE PIVOT	2
10	504153-001	PIVOT PIN, POTHOLE WELDMENT	2
11	066735-001	WELDMENT, POTHOLE	1
12	503800-001	MAIN MANIFOLD BLOCK	1
13	504536-000	PUMP ASSEMBLY	1
14	504133-000	BRACKET, GUIDE PAD ANGLE	1
15	504134-000	GUIDE PAD	1
16	500858-001	SPLIT PIN	1
17	504132-000	HYDRAULIC CYLINDER, POTHOLE	1
18	504023-000	MOUNTING PLATE, HYDRAULIC BLOCK	1

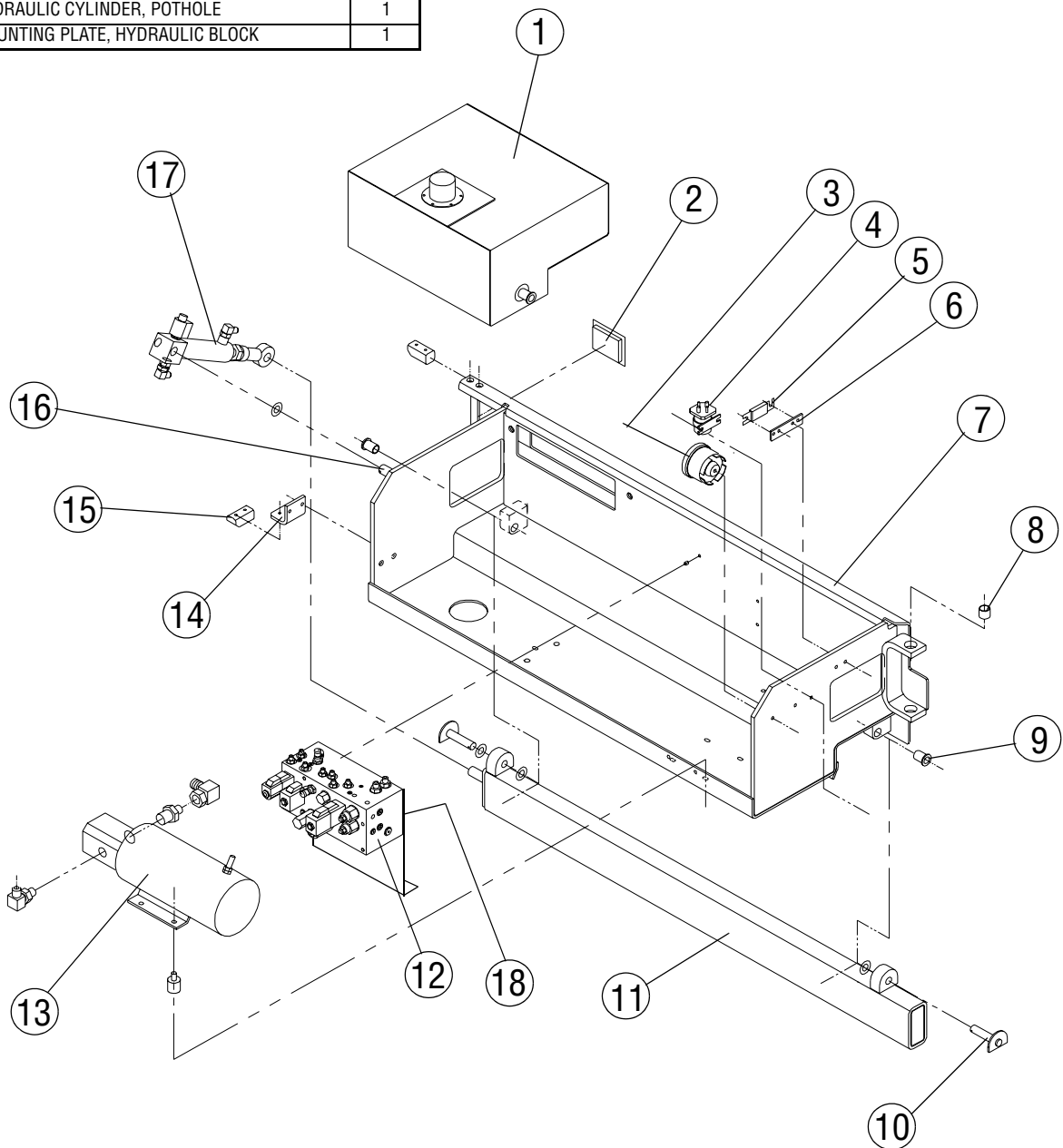

Control Valve Assembly

503800-000

Item	Part	Description	QTY.
1		TEST PORT	1
2	058358-000	FITTING, 1/4" - 1/4" MALE/MALE	1
3	058358-000	FITTING, 1/4" - 1/4" MALE/MALE	1
4	058358-000	FITTING, 1/4" - 1/4" MALE/MALE	1
5	057122-000	FITTING, 3/8" - 3/8" MALE/MALE	1
6	057122-000	FITTING, 3/8" - 3/8" MALE/MALE	1
7	058590-000	FITTING, 1/4 M/M ADAPTOR WITH 1mm OROFICE	1
8	057122-000	FITTING, 3/8" - 3/8" MALE/MALE	1
9	057358-000	FITTING, 1/4" - 1/4" MALE/MALE	1
10	-	-	-
11	057377-000	FITTING, 1/2" - 1/2" (MALE/MALE)	1
12	503802-000	CHECK VALVE, POTHOLE	1
13	503803-000	CROSS LINE RELIEF VALVE (DRIVE)	1
14	503804-000	VALVE, SOLENOID (DRIVE)	1
15	503805-000	VALVE, SOLENOID (DRIVE/LIFT)	1
16	503803-000	CROSS LINE RELIEF VALVE (DRIVE)	1
17	503807-000	PRESSURE RELIEF (MAIN LIFT)	1
18	503808-000	VALVE, SOLENOID (STEERING)	1
19	503809-000	FLOW RESTRICTOR (STEERING)	1
20	503810-000	RELIEF VALVE (STEERING)	1
21	057122-000	FITTING, 3/8" - 3/8" MALE/MALE	1
22	503810-000	RELIEF VALVE (MAIN RELIEF)	1
23	500303-000	COIL 18V	6

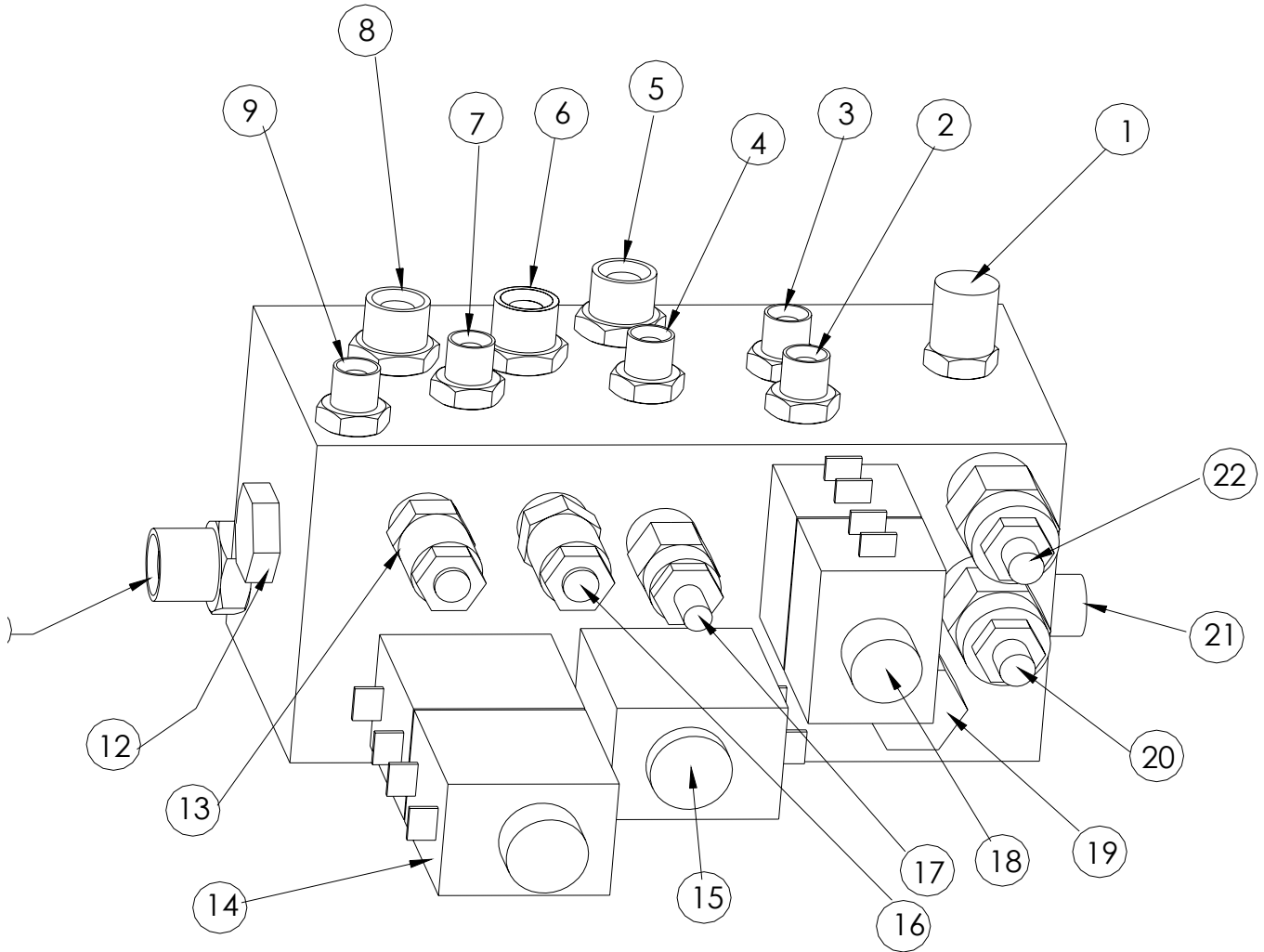

Lower Controls Assembly

504348-000

Item	Part	Description	QTY.
1	504141-000	COVER, LOWER CONTROL BOX	1
2	504142-000	BOX, LOWER CONTROL BOX	1
3	501867-000	EMERGENCY STOP BUTTON	1
4	502251-000	TOGGLE SWITCH	1
5	502250-000	ENABLE BUTTON	1
6	502544-000	KEY	1
7	502589-000	KEY SWITCH	1

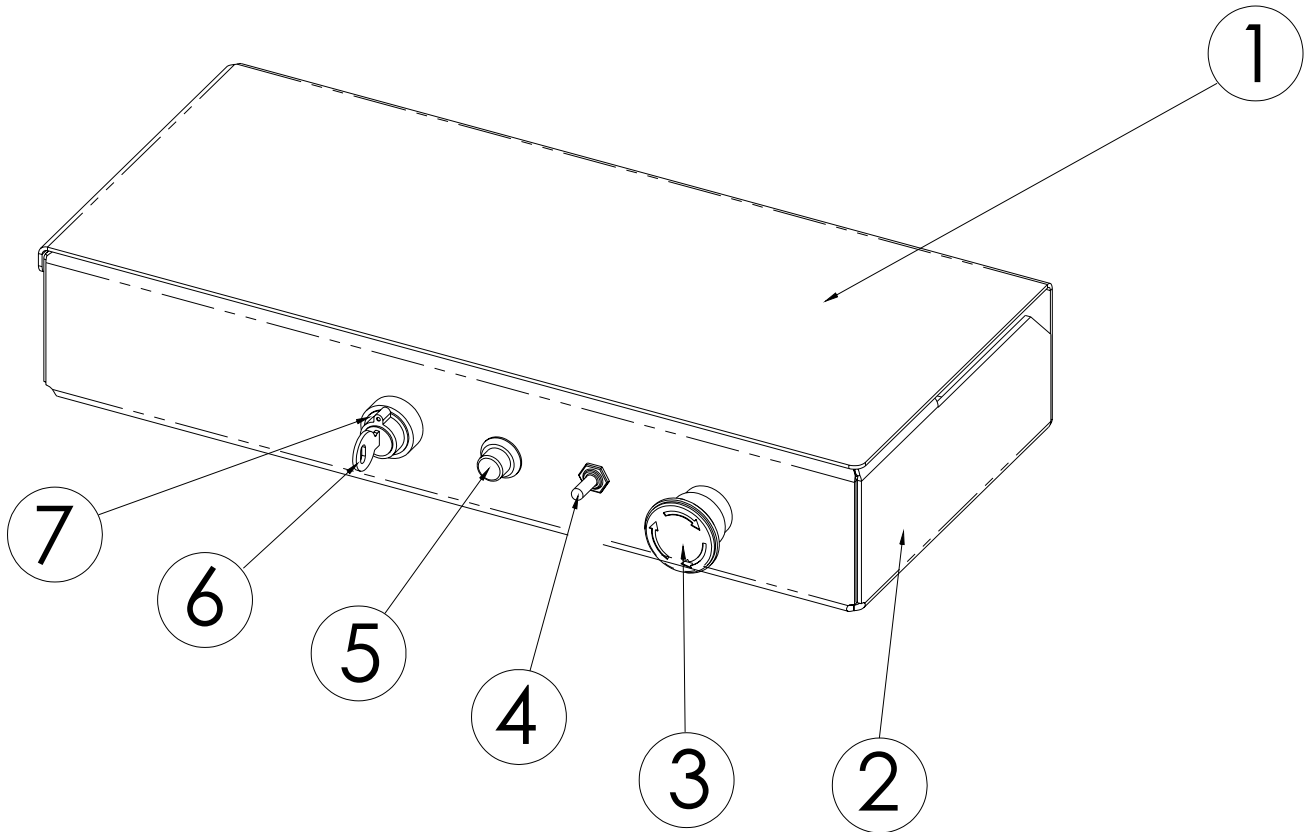

Hydraulic Tank Assembly

504128-001

Item	Part	Description	QTY.
1	-	TANK WELDMENT	1
2	057534-000	FILLER, BREATHER & DIPSTICK (CAP)	1
3	-	INSPECTION COVER & GASKET	1
4	057377-000	HYDRAULIC FITTING (1/2" M/M BSP)	1
5	057358-000	HYDRAULIC FITTING (1/4" M/M BSP)	1
6	058350-000	HYDRAULIC FITTING (3/4" BSP)	1
7	058359-000	SUCTION FILTER	1
8	057108-000	3/8 DRAIN PLUG	1

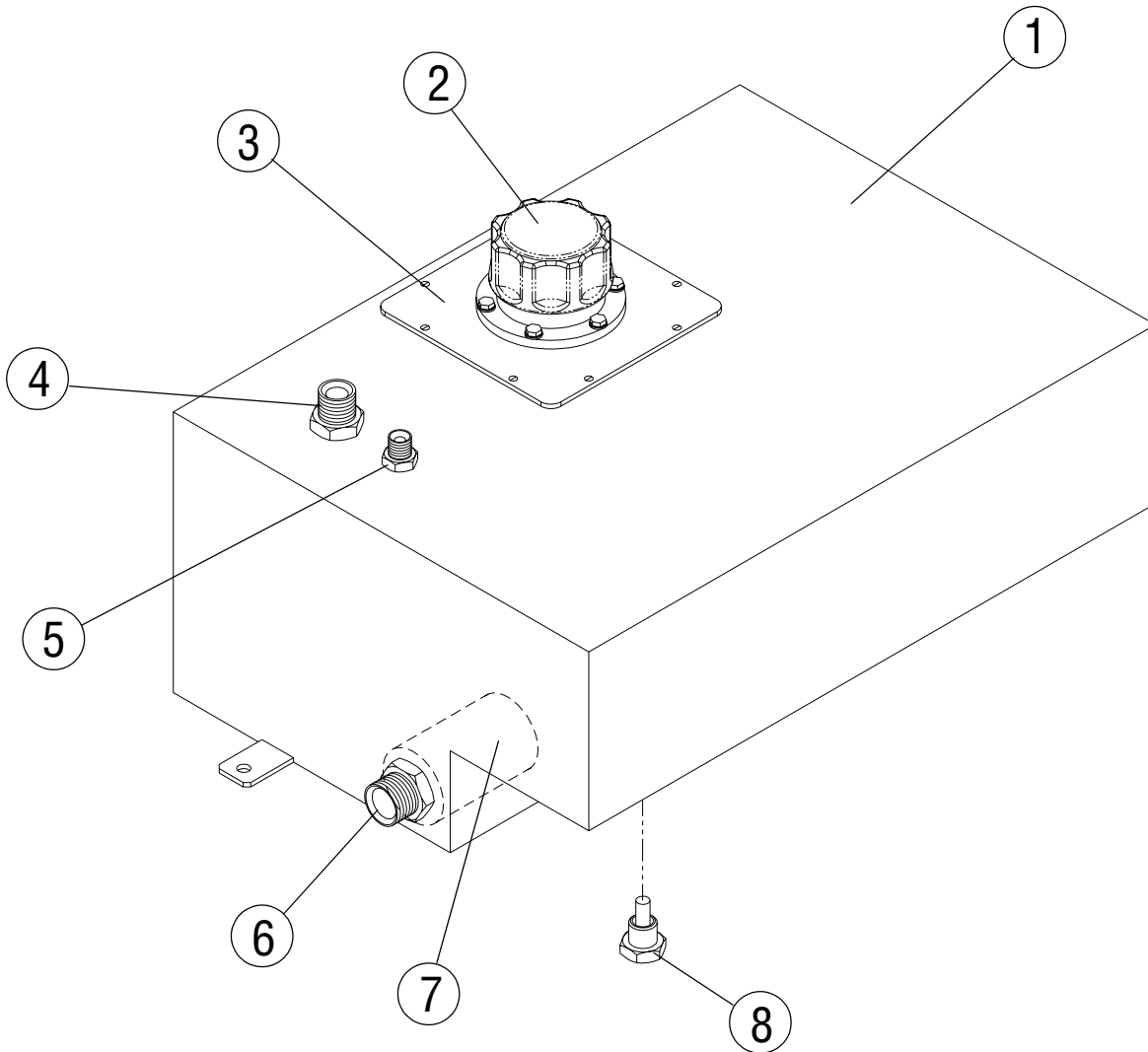

Upper Controls Assembly

504349-000

Item	Part	Description	QTY.
1	501867-000	EMERGENCY STOP BUTTON	1
2	501882-002	RUBBER BOOT, STEERING	1
3	501882-000	JOYSTICK	1
4	501882-001	RUBBER BOOT, JOYSTICK	1
5	502486-000	DECAL	1
6	501592-000	MOUNTING PLATE	1
7	502591-000	SEAL	1
8	502453-000	CIRCUIT BOARD	1
9	502587-001	SOCKET, MAIN HARNESS	1
10	502605-000	SOCKET, OVERLOAD	1
11	502496-000	UCB, BOX ONLY	1

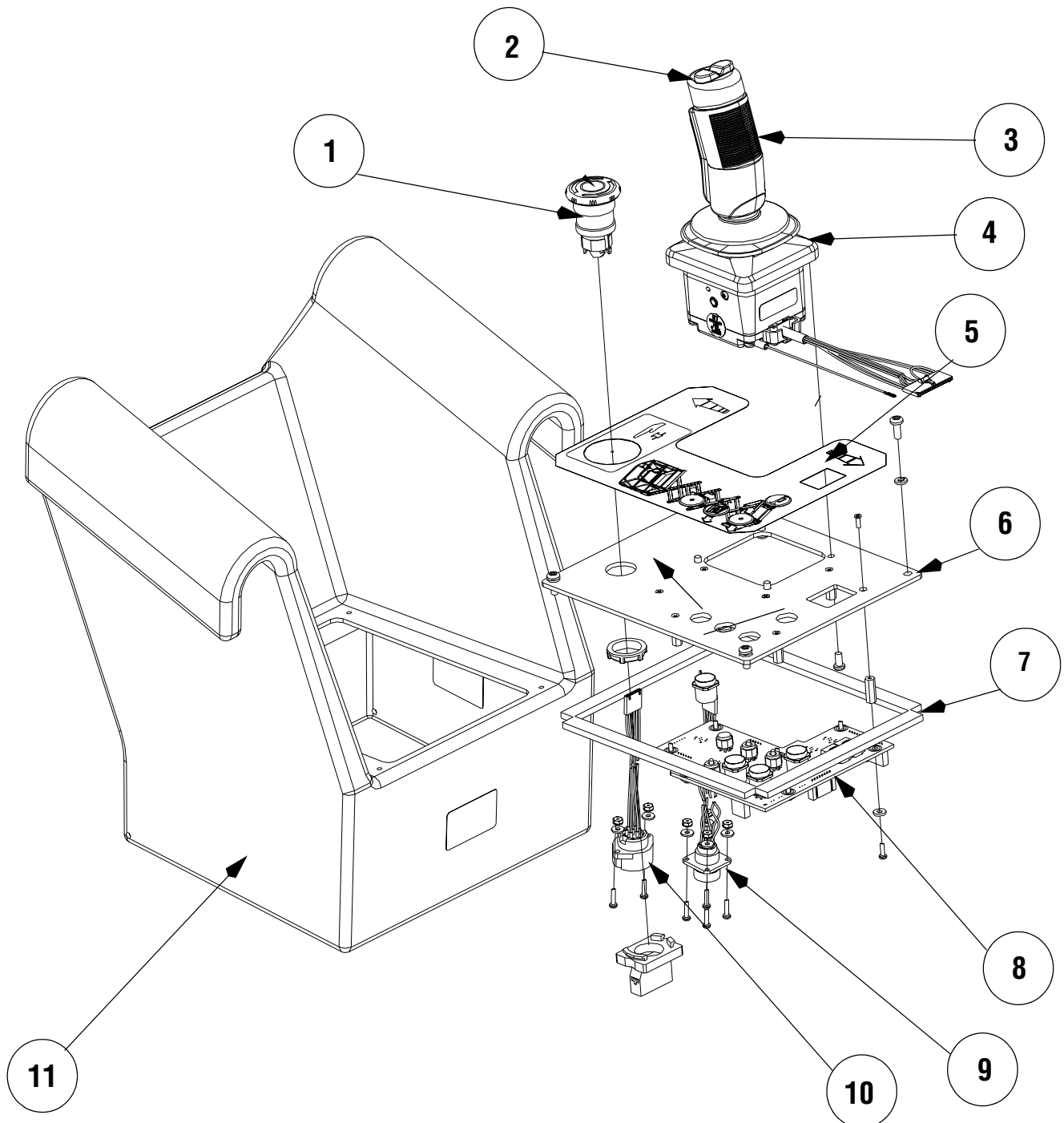

Hydraulic Block (Series / Parallel)

504151-000

Item	Part	Description	QTY.
1	500303-000	SOLENOID COIL 18V	2
2	057122-000	HYDRAULIC FITTING, 3/8 X 3/8 MALE MALE	4

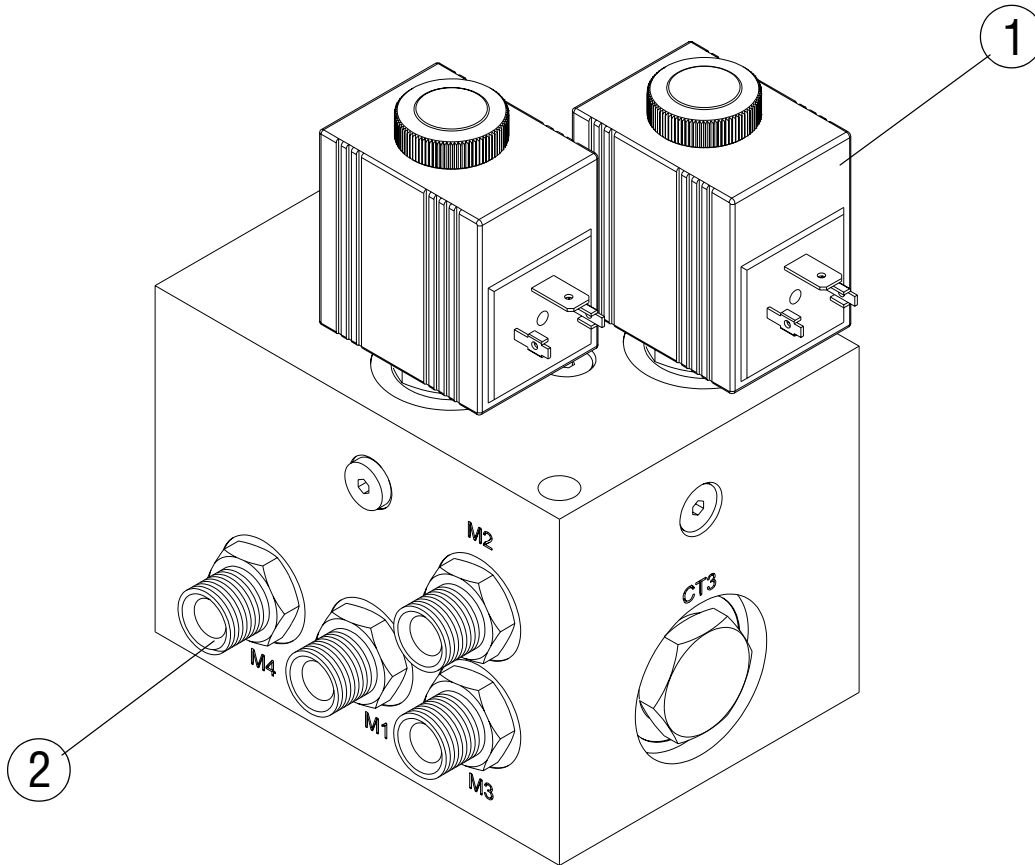

Hydraulic Assembly

504007-000 (X26)

Item	Part	Description	QTY.
1	504250-000	HYDRAULIC HOSE, BLOCK - SERIES/PARA BLOCK	1
2	504251-000	HYDRAULIC HOSE, BLOCK D2 - SERIES/PARA D2	1
3	504252-000	HYDRAULIC HOSE, SERIES/PARA BLOCK - MOTORS	4
4	504253-000	HYDRAULIC HOSE, BLOCK - BRAKE TEE	1
5	504254-000	HYDRAULIC HOSE, BRAKE TEE - MOTORS	2
6	504255-000	HYDRAULIC HOSE, BLOCK - STEERING CYLINDER	2
7	504256-000	HYDRAULIC HOSE, BLOCK - POTHOLE TEE	1
8	504257-000	HYDRAULIC HOSE, BLOCK - POTHOLE TEE	1
9	504260-000	HYDRAULIC HOSE, TEE (RHS) - POTHOLE CYL	1
10	504261-000	HYDRAULIC HOSE, TEE (RHS) - POTHOLE CYL	1
11	504258-000	HYDRAULIC HOSE, TEE (LHS) - POTHOLE CYL	1
12	504259-000	HYDRAULIC HOSE, TEE (LHS) - POTHOLE CYL	1
13	-	-	-
14	-	-	-
15	-	-	-
16	-	-	-
17	-	-	-
18	-	-	-
19	-	-	-
20	504269-000	HYDRAULIC HOSE, TANK - PUMP (SUCTION)	1
21	504270-000	HYDRAULIC HOSE, PUMP - BLOCK (PRESSURE)	1
22	504271-000	HYDRAULIC HOSE, BLOCK - FILTER (RETURN)	1
23	504272-000	HYDRAULIC HOSE, BLOCK - LIFT CYL	1
24	504273-000	HYDRAULIC HOSE, LIFT CYLINDER - TANK DRAIN	1
25	504128-001	HYDRAULIC TANK	1
26	504132-000	HYDRAULIC CYLINDER (POTHOLE)	2
27	114071-000	PUMP ASSEMBLY	1
28	503800-001	BLOCK, MAIN MANIFOLD	1
29	-	-	-
30	-	-	-
31	504129-000	HYDRAULIC CYLINDER, LIFT (LOWER)	1
32	504148-000	HYDRAULIC CYLINDER, STEER	1
33	504151-000	HYDRAULIC BLOCK, SERIES / PARALLEL	1
34	114055-000	MOTOR, HYDRAULIC	2
35	-	-	-

Hydraulic Assembly

504207-000 (X32)

1	504250-000	HYDRAULIC HOSE, BLOCK - SERIES/PARA BLOCK	1
2	504251-000	HYDRAULIC HOSE, BLOCK D2 - SERIES/PARA D2	1
3	504252-000	HYDRAULIC HOSE,SERIES/PARA BLOCK - MOTORS	4
4	504253-000	HYDRAULIC HOSE, BLOCK - BRAKE TEE	1
5	504254-000	HYDRAULIC HOSE, BRAKE TEE - MOTORS	2
6	504255-000	HYDRAULIC HOSE, BLOCK - STEERING CYLINDER	2
7	504256-000	HYDRAULIC HOSE, BLOCK - POTHOLE TEE	1
8	504257-000	HYDRAULIC HOSE, BLOCK - POTHOLE TEE	1
9	504260-000	HYDRAULIC HOSE, TEE (RHS) - POTHOLE CYL	1
10	504261-000	HYDRAULIC HOSE, TEE (RHS) - POTHOLE CYL	1
11	504258-000	HYDRAULIC HOSE, TEE (LHS) - POTHOLE CYL	1
12	504259-000	HYDRAULIC HOSE, TEE (LHS) - POTHOLE CYL	1
13	-	-	-
14	504263-000	HYDRAULIC HOSE, PRESSURE SWITCH - LWR LIFT TEE	1
15	504264-000	HYDRAULIC HOSE, TEE - LIFT CYL LOWER	1
16	504265-000	HYDRAULIC HOSE, TEE - LIFT CYL UPPER	1
17	504266-000	HYDRAULIC HOSE, LIFT CYL UPPER - DRAIN TEE	1
18	504267-000	HYDRAULIC HOSE, LIFT CYL LOWER - DRAIN TEE	1
19	504268-000	HYDRAULIC HOSE, DRAIN TEE - TANK	1
20	504269-000	HYDRAULIC HOSE, TANK - PUMP (SUCTION)	1
21	504270-000	HYDRAULIC HOSE, PUMP - BLOCK (PRESSURE)	1
22	504271-000	HYDRAULIC HOSE,BLOCK - FILTER (RETURN)	1
23	-	-	-
24	-	-	-
25	504128-001	HYDRAULIC TANK	1
26	504132-000	HYDRAULIC CYLINDER (POTHOLE)	2
27	114071-000	PUMP ASSEMBLY	1
28	503800-001	BLOCK, MAIN MANIFOLD	1
29	-	-	-
30	504124-000	HYDRAULIC CYLINDER, LIFT (UPPER)	1
31	504129-000	HYDRAULIC CYLINDER, LIFT (LOWER)	1
32	504148-000	HYDRAULIC CYLINDER, STEER	1
33	504151-000	HYDRAULIC BLOCK, SERIES / PARALLEL	1
34	114055-000	MOTOR, HYDRAULIC	2
35	-	-	-
1	504250-000	HYDRAULIC HOSE, BLOCK - SERIES/PARA BLOCK	1
2	504251-000	HYDRAULIC HOSE, BLOCK D2 - SERIES/PARA D2	1
3	504252-000	HYDRAULIC HOSE,SERIES/PARA BLOCK - MOTORS	4
4	504253-000	HYDRAULIC HOSE, BLOCK - BRAKE TEE	1
5	504254-000	HYDRAULIC HOSE, BRAKE TEE - MOTORS	2

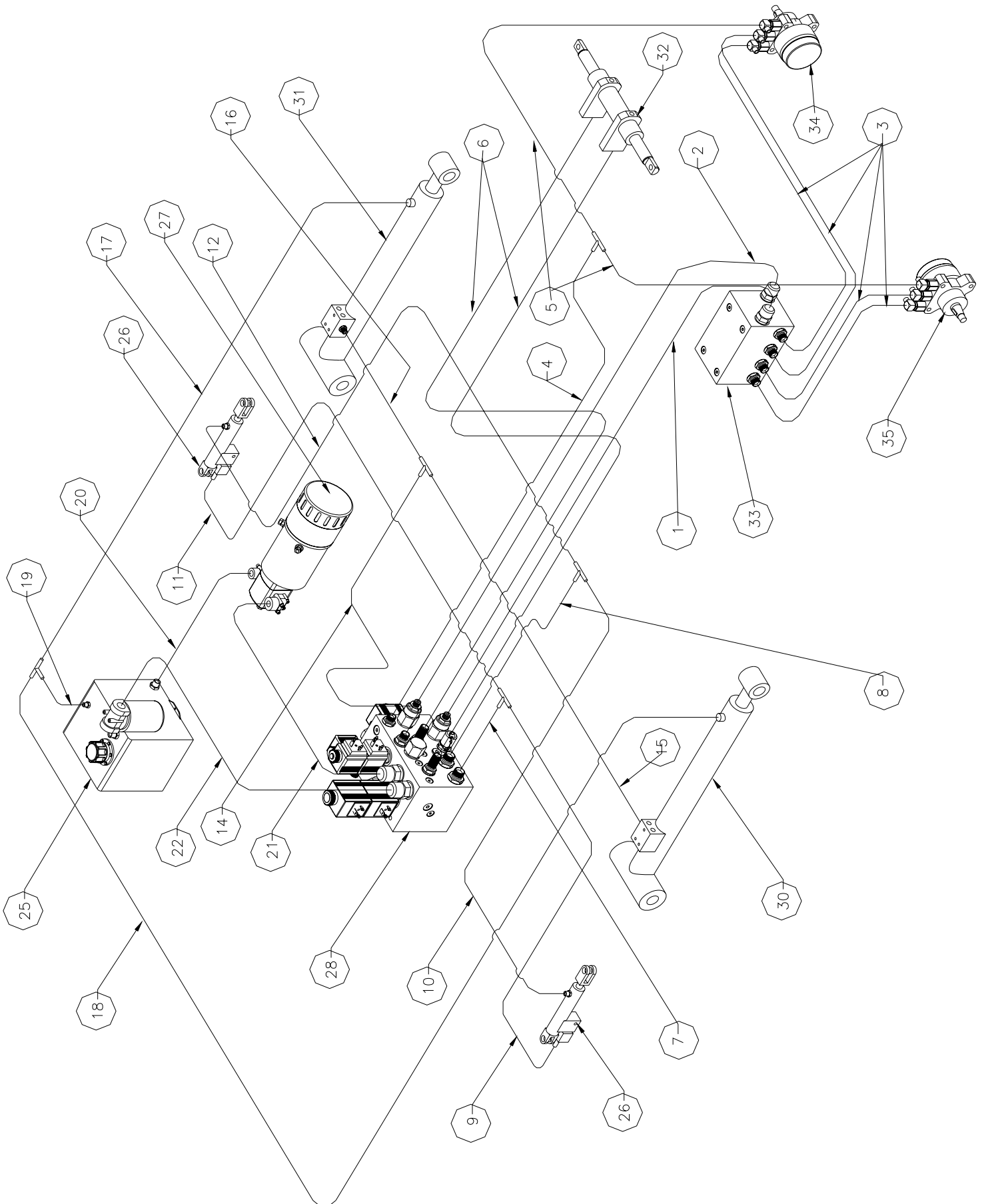

Hydraulic Cylinder Assembly (Lift, Lower)

X26 & X32

504129-001 (ANSI 504129-002)

Item	Part	Description	QTY.
1	-	CYLINDER BODY	1
2	-	SOLENOID VALVE (EMERGENCY DOWN)	1
3	-	LOCK NUT	1
4	-	PISTON HEAD	1
5	504129-010	SEAL KIT	1
6	-	SPACING SLEEVE	1
7	-	CAP, BODY END	1
8	-	CYLINDER ROD	1
9	504120-000	FLANGED BUSHING	4
10	058819-000	M6 GREASE NIPPLE	2

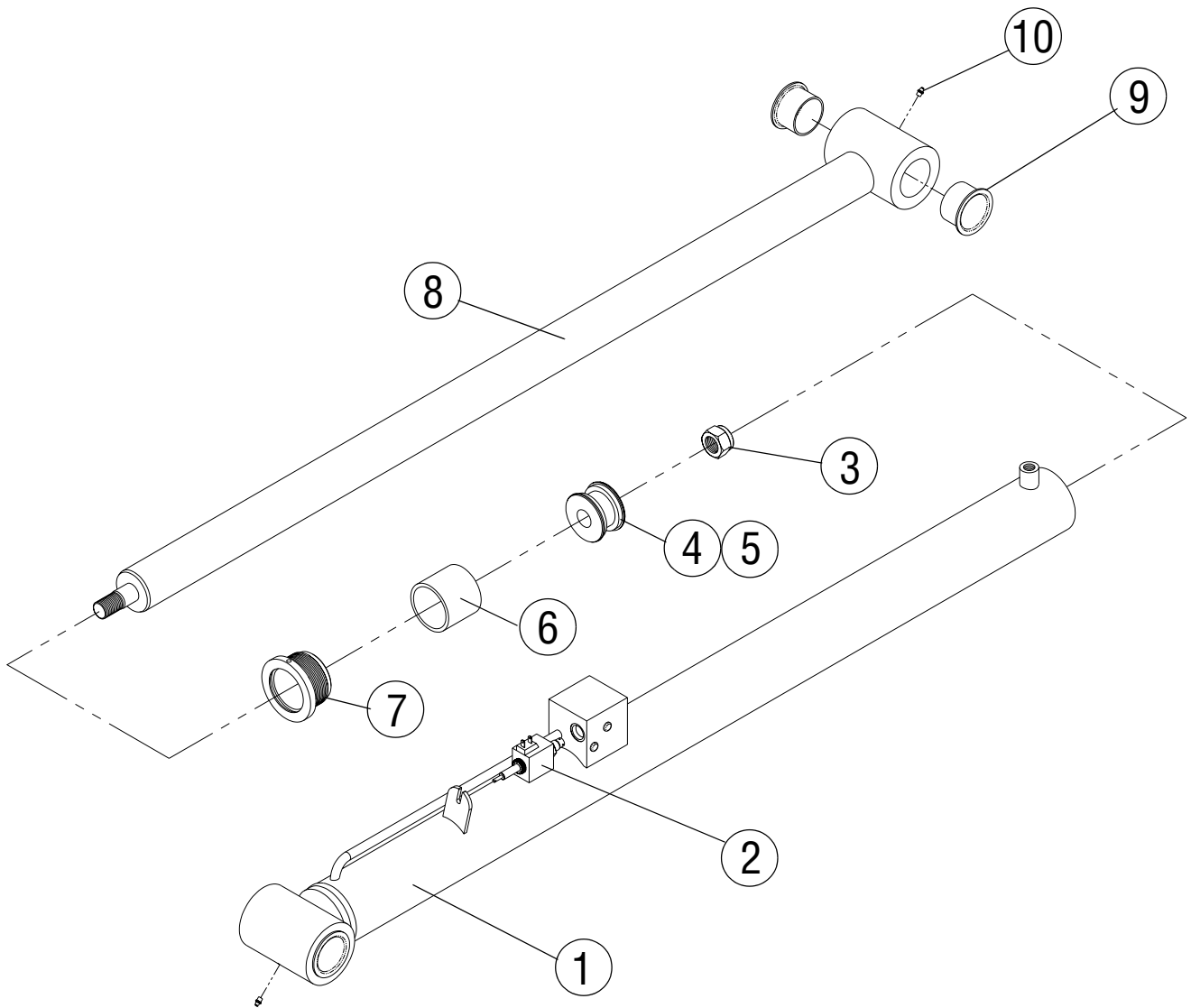

Hydraulic Cylinder Assembly (Lift, Upper)

X32 ONLY

504124-001 (ANSI 504124-002)

Item	Part	Description	QTY.
1	-	CYLINDER BODY	1
2	-	SOLENOID VALVE (EMERGENCY DOWN)	1
3	-	LOCK NUT	1
4	-	PISTON HEAD	1
5	504124-010	SEAL KIT	1
6	-	SPACING SLEEVE	1
7	-	CAP, BODY END	1
8	-	CYLINDER ROD	1
9	504120-000	FLANGED BUSHING	4
10	058819-000	M6 GREASE NIPPLE	2

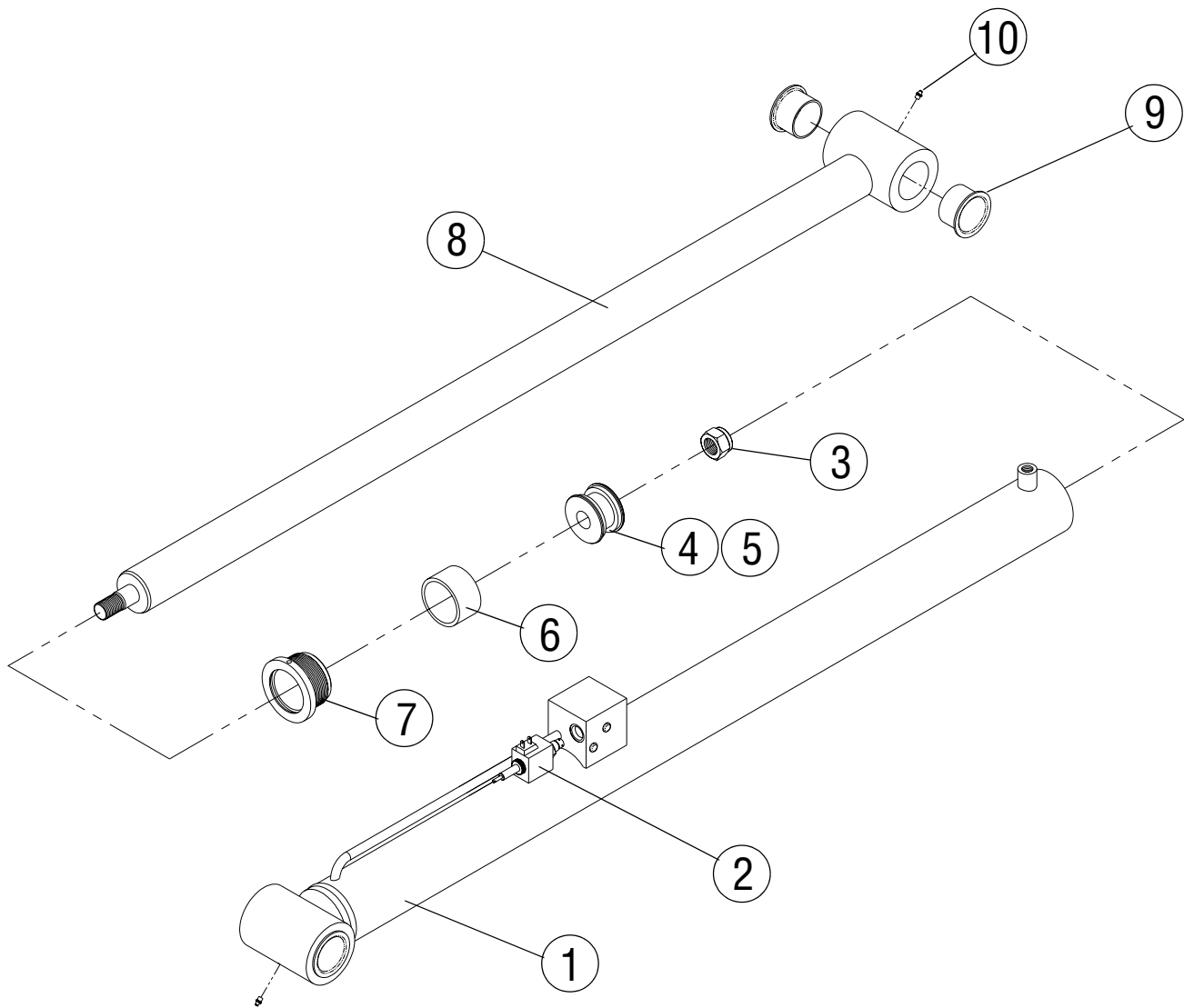

Hydraulic Cylinder Assembly (Steer)

504148-000

Item	Part	Description	QTY.
1	-	CYLINDER BODY	
2	-	LOCK NUT	
3	-	PISTON HEAD	
4	504148-010	SEAL KIT	
5	-	CAP, BODY END	
6	-	CYLINDER ROD	

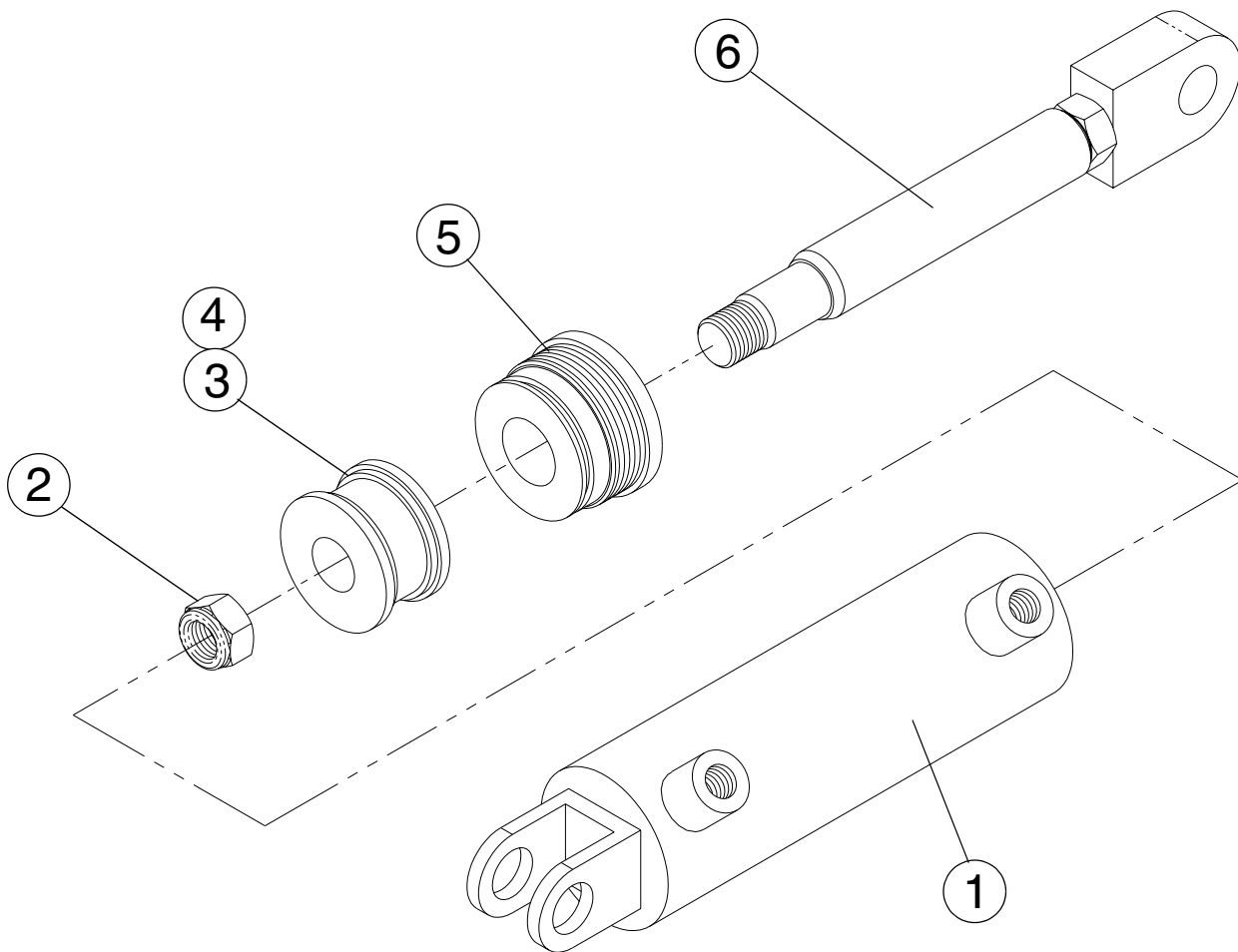

Hydraulic Cylinder Assembly (Pothole)

504132-000

Item	Part	Description	QTY.
1	-	CYLINDER BODY	1
2	-	SOLENOID VALVE	1
3	-	LOCK NUT	1
4	-	PISTON HEAD	1
5	504132-010	SEAL KIT	1
6	-	CAP, BODY END	1
7	-	CYLINDER ROD	1

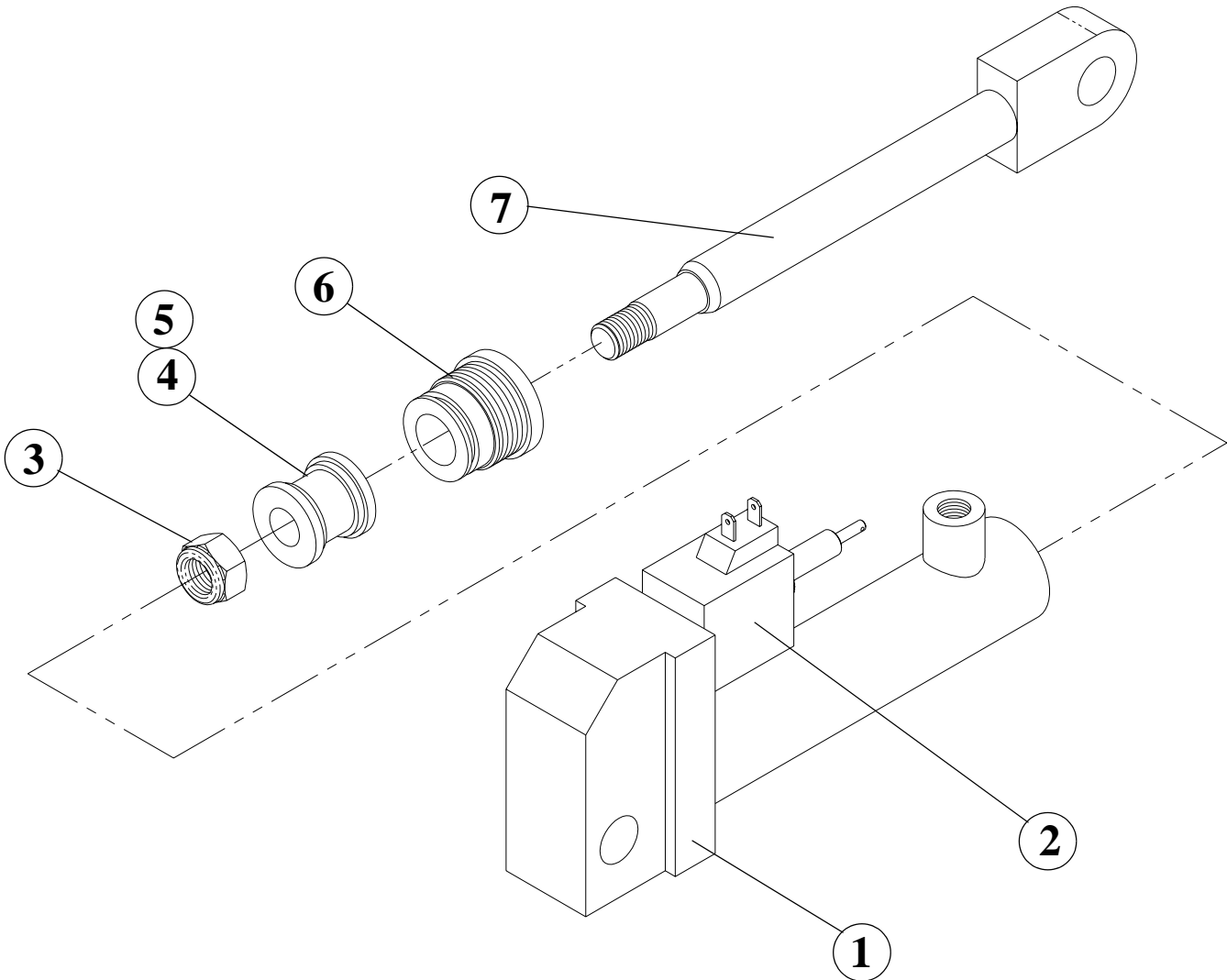

Electrical Assembly X26

504008-000

Item	Part	Description	QTY.
1	502483-000	ECU	1
2	502593-000	J1 HARNESS	1
3	503800-001	MAIN MANIFOLD BLOCK	1
4	505005-000	UPPER CONTROLS	1
5	505006-000	LOWER CONTROLS	1
6	058912-000	TILT SENSOR	1
7	501868-000	HORN	1
8	502588-000	ALARM	1
9	505072-000	PROXIMITY SENSOR	1
10	502494-000	FUSE	1
11	058937-000	BATTERY DISCONNECT PLUG	1
12	502594-000	HARNESS, BATTERY DISCONNECT - BATT (-)	1
13	502595-000	HARNESS, BATTERY DISCONNECT - BATT (+)	1
14	501074-000	BATTERY	4

Item	Part	Description	QTY.
15	502596-000	HARNESS, BATTERY INTERCONNECT	3
16	503097-000	CHARGER	1
17	058783-000	CHARGER DISCONNECT PLUG	1
18	502597-000	HARNESS, CHARGER DISCONNECT (+) - LINE CON4	1
19	502598-000	HARNESS, CHARGER DISCONNECT (-) - BATT (-)	1
20	502599-000	HARNESS, CHARGER DISCONNECT (-) - LINE CON2	1
21	502600-000	LINE CONTACTOR 3 - FUSE	1
22	502601-000	LINE CONTACTOR 5 - LINE CONTACTOR 3	1
23	502489-000	LINE CONTACTOR	1
24	502602-000	LINE CONTACTOR 2 - MOTOR CONT B-	1
25	502603-000	LINE CONTACTOR 1 - MOTOR CONT ENABLE	1
26	502604-000	LINE CONTACTOR 6 - PUMP MOTOR	1
27	502492-000	MOTOR CONTROLLER	1
28	114071-000	PUMP MOTOR	1

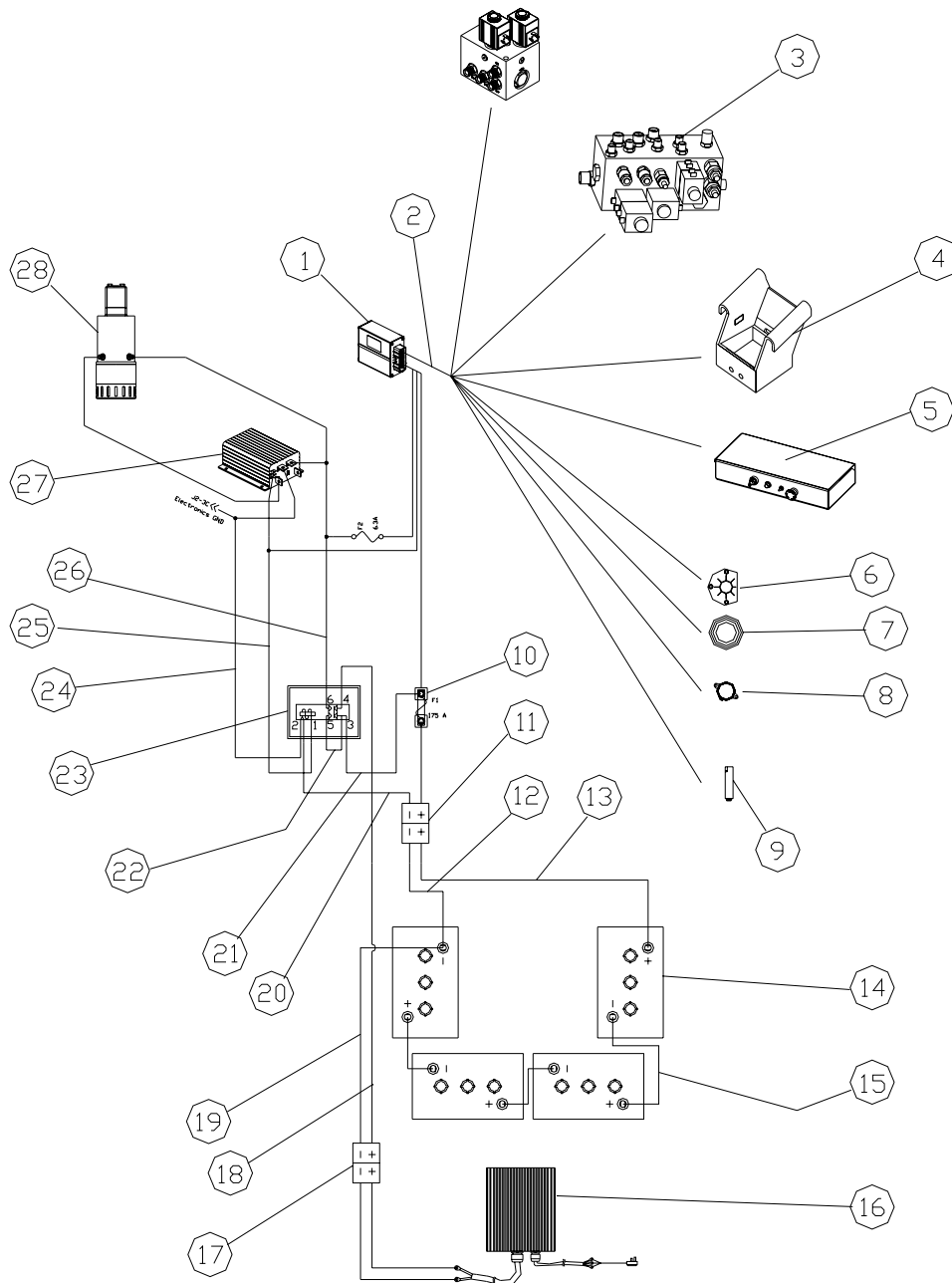

Electrical Assembly X32

504208-000

Item	Part	Description	QTY.
1	502483-000	ECU	1
2	502593-000	J1 HARNESS	1
3	503800-001	MAIN MANIFOLD BLOCK	1
4	505005-000	UPPER CONTROLS	1
5	505006-000	LOWER CONTROLS	1
6	058912-000	TILT SENSOR	1
7	501868-000	HORN	1
8	502588-000	ALARM	1
9	505072-000	PROXIMITY SENSOR	1
10	502494-000	FUSE	1
11	058937-000	BATTERY DISCONNECT PLUG	1
12	502594-000	HARNESS, BATTERY DISCONNECT - BATT (-)	1
13	502595-000	HARNESS, BATTERY DISCONNECT - BATT (+)	1
14	501074-000	BATTERY	4
15	502596-000	HARNESS, BATTERY INTERCONNECT	3
16	503097-000	CHARGER	1

Item	Part	Description	QTY.
17	058783-000	CHARGER DISCONNECT PLUG	1
18	502597-000	HARNESS, CHARGER DISCONNECT (+) - LINE CON4	1
19	502598-000	HARNESS, CHARGER DISCONNECT (-) - BATT (-)	1
20	502599-000	HARNESS, CHARGER DISCONNECT (-) - LINE CON2	1
21	502600-000	LINE CONTACTOR 3 - FUSE	1
22	502601-000	LINE CONTACTOR 5 - LINE CONTACTOR 3	1
23	502489-000	LINE CONTACTOR	1
24	502602-000	LINE CONTACTOR 2 - MOTOR CONT B-	1
25	502603-000	LINE CONTACTOR 1 - MOTOR CONT ENABLE	1
26	502604-000	LINE CONTACTOR 6 - PUMP MOTOR	1
27	502492-000	MOTOR CONTROLLER	1
28	114071-000	PUMP MOTOR	1
29	504151-000	HYDRAULIC BLOCK, SERIES / PARALLEL	1
30	504374-000	EMERGENCY DOWN ASSEMBLY	1
31	504169-000	BATTERY, EMERGENCY DOWN	2

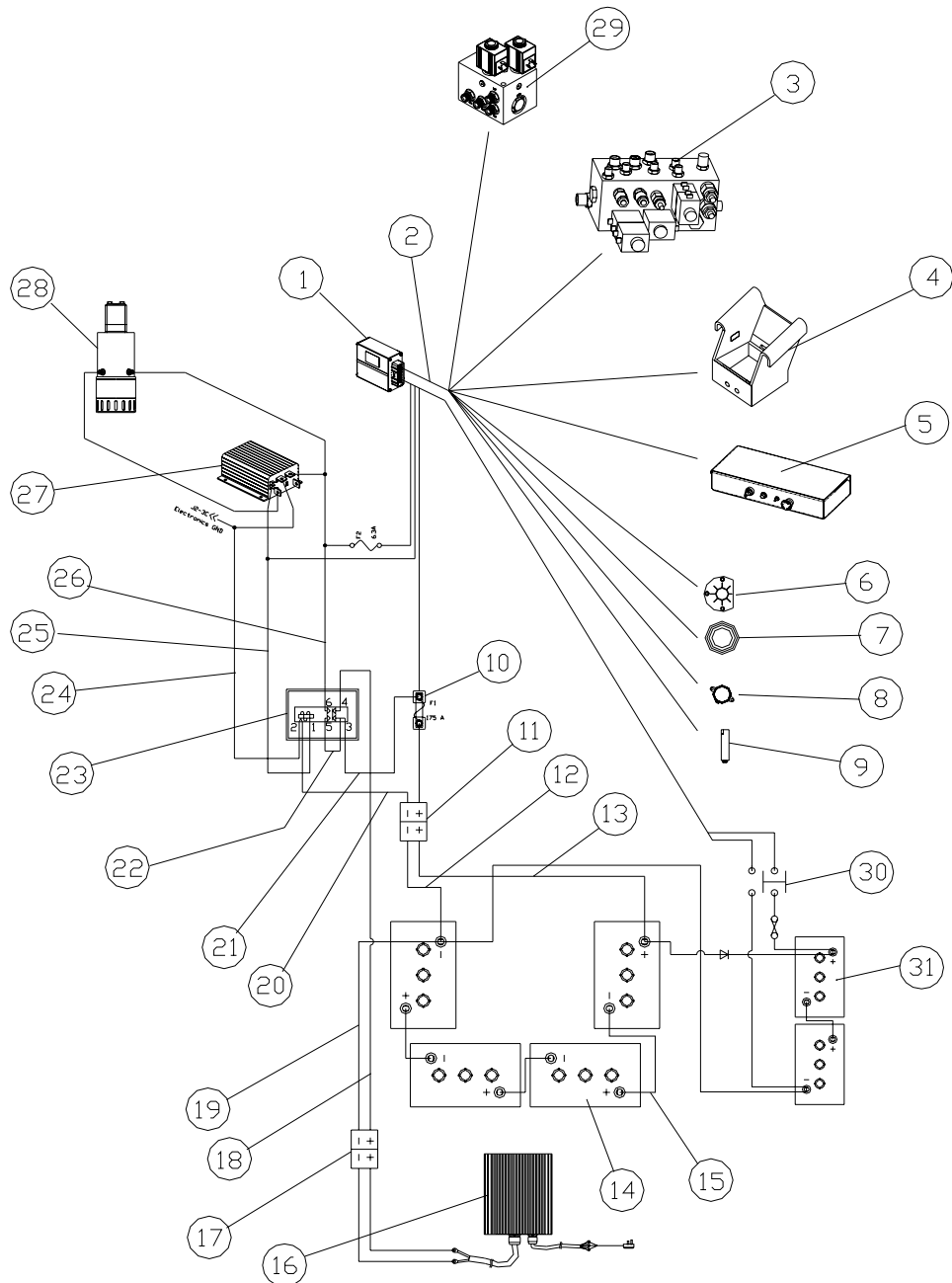

Overload Assembly

504557-000

Item	Part	Description	QTY.
1	503950-000	MOUNTING PLATE, ELECTRICAL BOX	1
2	504566-000	MOUNTING PLATE, CIRCUIT BOARD	1
3	504558-000	CIRCUIT BOARD	1
4	504559-000	ANGLE TRANSDUCER	1
5	504560-000	PRESSURE TRANSDUCER	1

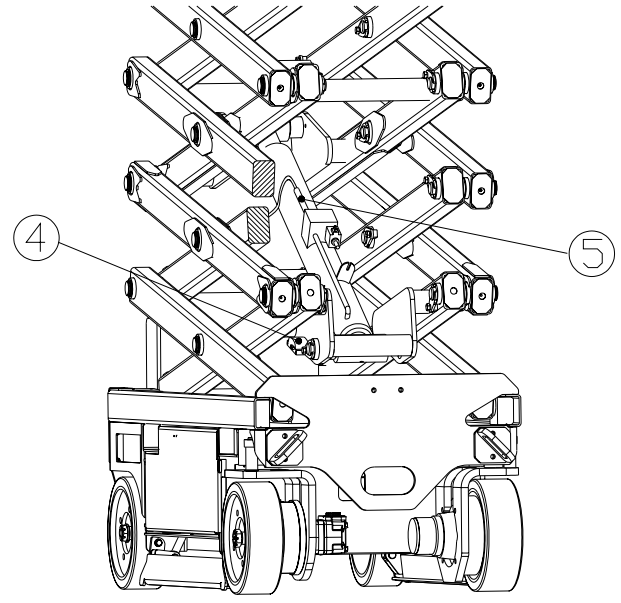
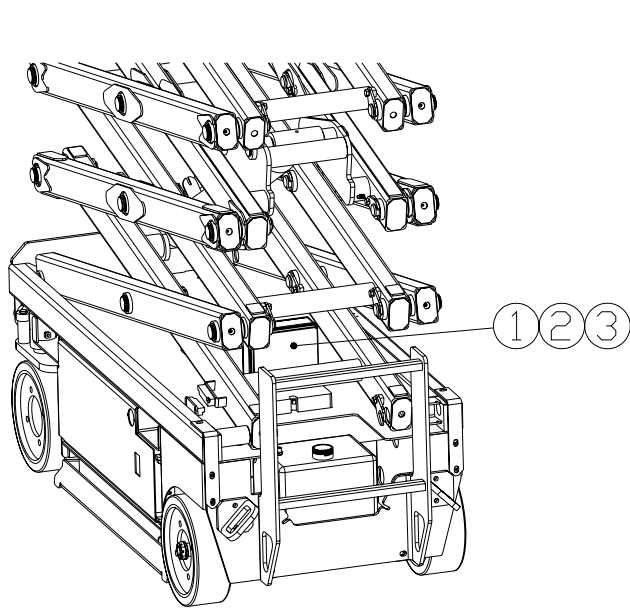

Notes :

Decal Assembly X26

504009-000

Item	Part	Description	QTY.
1	101210-000	DECAL, HYDROGEN GAS	1
2	066551-950	DECAL, SAFE WORKING LOAD (EXT DECK)	1
3	504199-002	DECAL, SAFE WORKING LOAD (MAIN DECK)	1
4	014222-903	DECAL, FORKLIFT POINT	1
5	503724-000	DECAL, WARNING CRUSHING (HAND)	2
6	060197-000	DECAL, HYDRAULIC FLUID	1
7	100102-900	DECAL, NOT INSULATED	1
8	066561-902	DECAL, SCISSOR BRACE	1
9	005223-906	DECAL, EMERGENCY DOWN	1
10	010076-901	DECAL, DOCUMENTS ENCLOSED	1
11	066556-900	DECAL, DANGER ABOVE	2
12	503721-000	DECAL, LOWER CONTROL BOX	1

Item	Part	Description	QTY.
13	062562-951	DECAL, BATTERIES ARE BALLAST	2
14	502486-000	DECAL, UPPER CONTROL BOX	1
15	066522-900	DECAL, BATTERY SYMBOL	1
16	501453-000	DECAL, WARNING CRUSHING (FOOT)	4
17	503723-000	DECAL, BATTERY DISCONNECT	1
18	068635-001	DECAL, HARNESS HARDPOINT	2
19	067195-001	DECAL, THREE HAZARDS (ENGLISH)	1
19	067195-201	DECAL, THREE HAZARDS (GERMAN)	1
19	067195-301	DECAL, THREE HAZARDS (FRENCH)	1
20	107053-000	DECAL, HORN	1
21	504193-000	DECAL, LIVERY (X26)	2
22	504196-000	DECAL, "UpRight" (LARGE)	2

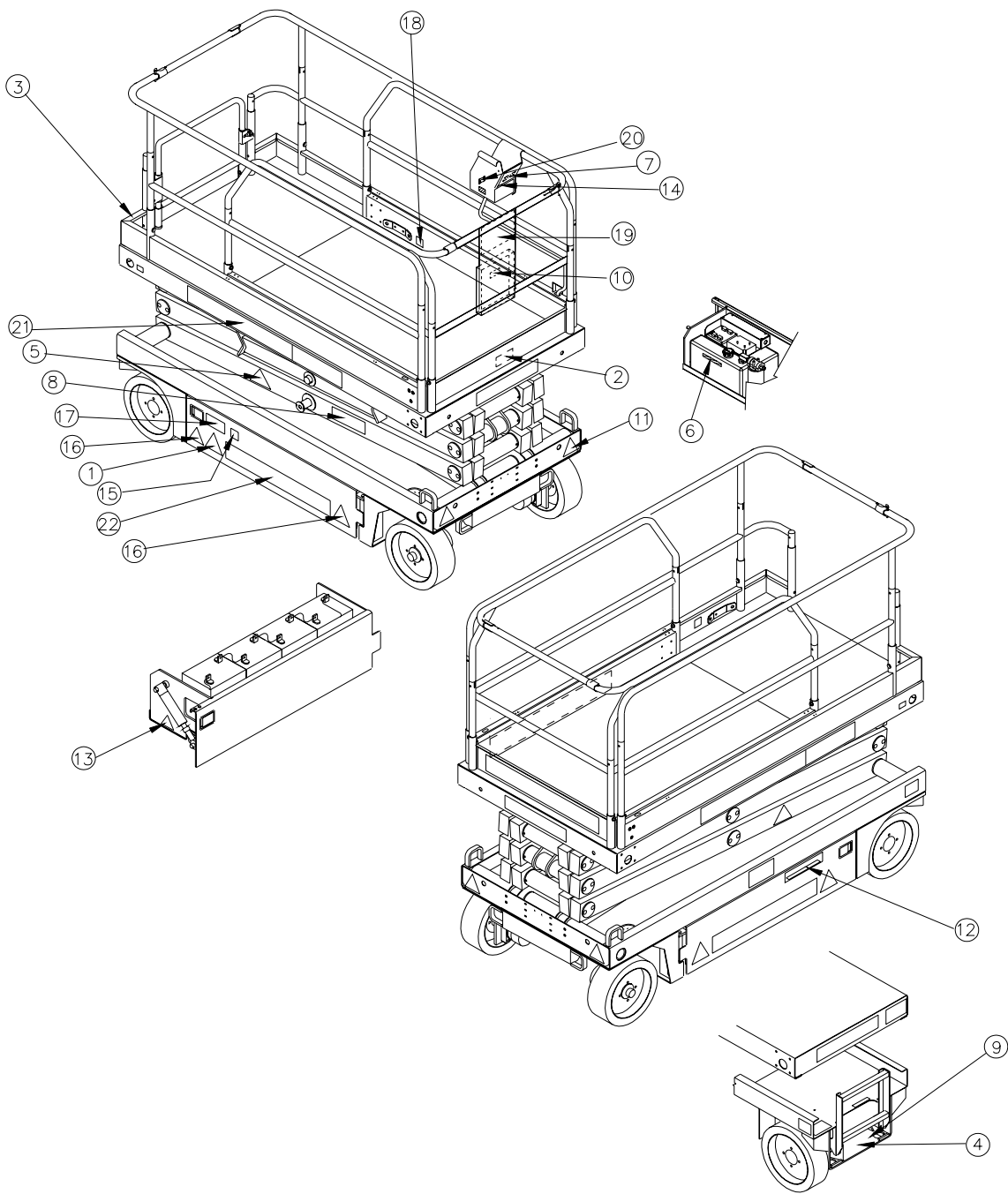

Decal Assembly X32

504209-000

Item	Part	Description	QTY.
1	101210-000	DECAL, HYDROGEN GAS	1
2	066551-950	DECAL, SAFE WORKING LOAD (EXT DECK)	1
3	504199-007	DECAL, SAFE WORKING LOAD (MAIN DECK)	1
4	014222-903	DECAL, FORKLIFT POINT	1
5	503724-000	DECAL, WARNING CRUSHING (HAND)	2
6	060197-000	DECAL, HYDRAULIC FLUID	1
7	100102-900	DECAL, NOT INSULATED	1
8	066561-902	DECAL, SCISSOR BRACE	1
9	005223-908	DECAL, EMERGENCY DOWN	1
10	010076-901	DECAL, DOCUMENTS ENCLOSED	1
11	066556-900	DECAL, DANGER ABOVE	2
12	503721-000	DECAL, LOWER CONTROL BOX	1

Item	Part	Description	QTY.
13	062562-951	DECAL, BATTERIES ARE BALLAST	2
14	502486-000	DECAL, UPPER CONTROL BOX	1
15	066522-900	DECAL, BATTERY SYMBOL	1
16	501453-000	DECAL, WARNING CRUSHING (FOOT)	4
17	503723-000	DECAL, BATTERY DISCONNECT	1
18	068635-001	DECAL, HARNESS HARDPOINT	2
19	067195-001	DECAL, THREE HAZARDS (ENGLISH)	1
19	067195-201	DECAL, THREE HAZARDS (GERMAN)	1
19	067195-301	DECAL, THREE HAZARDS (FRENCH)	1
20	107053-000	DECAL, HORN	1
21	504194-000	DECAL, LIVERY (X26)	2
22	504196-000	DECAL, "UpRight" (LARGE)	2

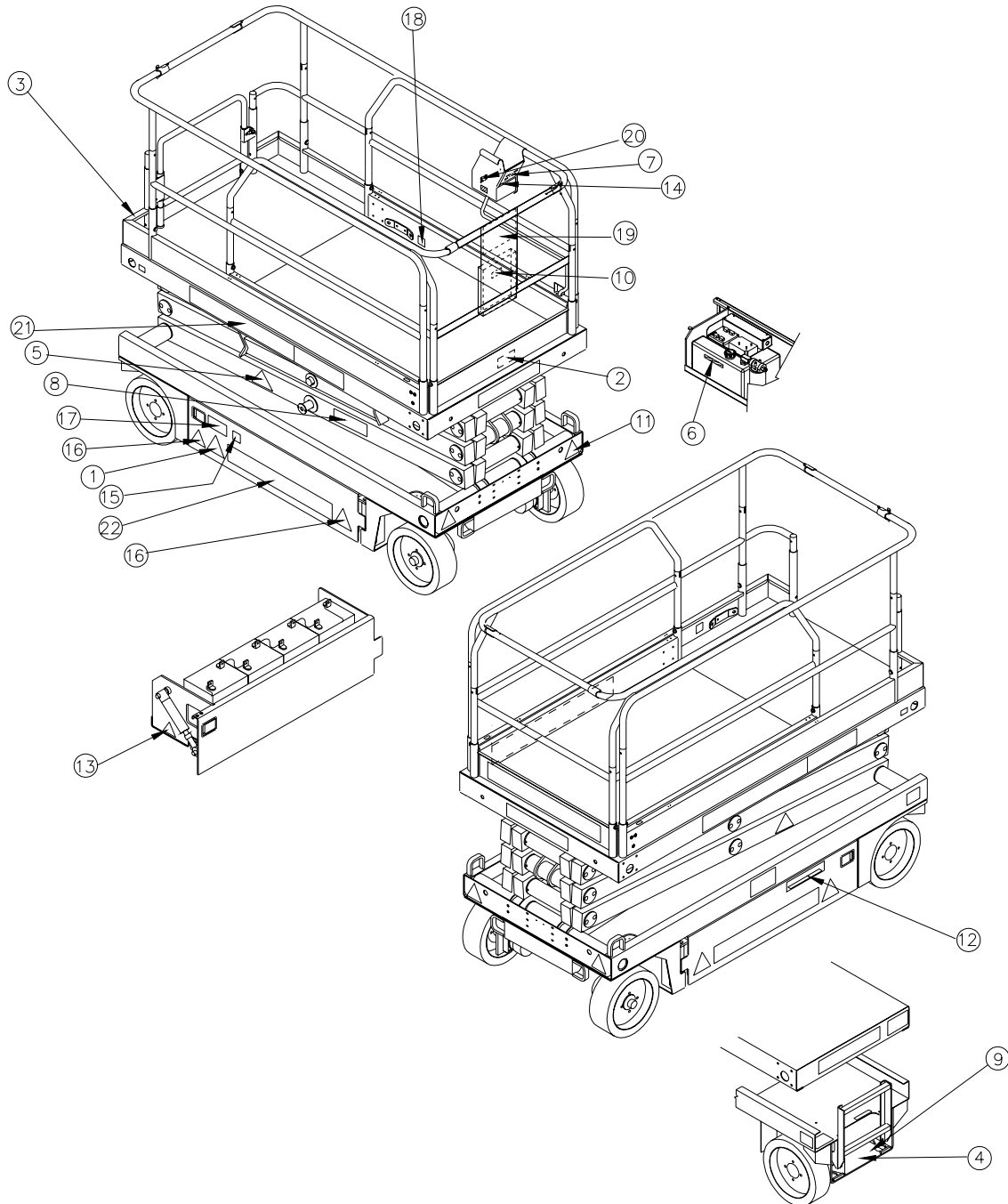

Local Distributor:

Lokaler Vertriebshändler:

Distributeur local:

El Distribuidor local:

Il Distributore locale:

USA

TEL: +1 (559) 443 6600
FAX: +1 (559) 268 2433

UpRight
POWERED ACCESS

www.upright.com

Europe

TEL: +44 (0) 845 1550 058
FAX: +44 (0) 195 2299 948